

**2019 - 2020 - 2021 SEASON**



# ***RULES AND REGULATIONS***

Revised October 31, 2018

## **Rule Book Disclaimer**

The rules and/or regulations set forth herein are designed to provide for the orderly conduct of racing events and to establish minimum acceptable requirements for such events. These rules shall govern the condition of all events, and by participating in these events, all participants are deemed to have complied with these rules. No express or implied warranty of safety shall result from the publications of or compliance with these rules and regulations. They are intended as a guide for the conduct of the sport and are no way a guarantee against injury or death to a participant, spectator or official.

The race director shall be empowered to permit minor deviation from any of the specifications herein or impose any further restrictions that, in his opinion, do not alter the minimum acceptable requirements. No express or implied warranty of safety shall result from such alteration of specifications. Any interpretation or deviation of these rules is left to the discretion of the officials. Their decision is final.

Since it would be both impractical and impossible to list within the confines of any rule book all modifications, adaptations, and infractions that could be or would be illegal, it shall be understood for the purpose of rule book enforcement that only those items that are specified in this booklet are allowable and permissible. In addition, Speedway 95 holds the rights to fine, suspend, eject and/or withhold purse and points from anyone who violates these rules.

Motorsports at all levels pose a risk to your wellbeing. Following the rules set for by Speedway 95 in no way guarantees or suggests your safety.

Technical rules that are changed during the race season will be posted on the company web page [www.speedway95racing.com](http://www.speedway95racing.com) under the tech page.

## **Point System For All Divisions**

Feature winners in all divisions are awarded 100 points. Each position back is awarded two (2) less points than the previous position. Heat winners in all divisions are awarded 10 points for winning, and each position back receives two (2) points less than the previous position except 6th position receives one (1) point. No points are awarded for non-qualifier/consolation events in any division. Drivers must make an attempt to complete one lap under green flag conditions during a feature race to receive feature points and purse. Points are awarded to the driver. Purse money is paid to the person listed on the information sheet for that vehicle under "Check payable to". Any other arrangements are between that person and the driver.

In case of tie finishes where a clear and convincing winner cannot be determined, the purses and points for both or all positions in question will be pooled and divided amongst the drivers involved.

**Any discrepancy in points or finishes must be addressed within 2 weeks of event.**

**Competitor must compete in minimum of 3/4 of the scheduled race events to qualify for any trophies.**

**Drivers that participate in Series races will receive 25 regular season points per series race participating in**

## Number Rules

1. All numbers will be assigned by Kim 207-356-9516 (Text or call). An assigned number may be retained for the following season if the driver assigned that number competed in at least ten (10) race meets during the previous season and the driver is remaining in the same division. When changing divisions, a new number will be assigned.
2. A minimum of 18 in. high and 3 in. wide **block style** number is required centered on the door area of both sides of the car. A minimum 30 in. high, 3 in. **wide block style** number is required to be located on the roof of the car and it must be readable from the right side of the car. A 20 in. high and 3 in. wide number must also be located on the trunk, readable from the rear. Numbers shall be painted neatly in a color contrasting that of the car. Windshield numbers at least 5 in. high are required on the far upper right-hand side of the windshield. All A block style number as large as possible on the outer headlight and taillight covers is recommended. Any car not following number rules will not be scored.
3. Three digit numbers and fractions are not allowed. No new numbers will be issued with any number/letter combination.
4. All numbers must be kept in easily readable condition. If they are damaged in an accident, they must be fixed by the next race meet. Inability of the scorers to read numbers can result in the car being barred from competition until they are repaired to the satisfaction of head judge.

## Line Ups

All divisions will draw for heat starting positions. Car and Driver must be present at the time of drawing. Number of heats will be decided after draw takes place.

**Heats:** Cars will be lined up by order of draw position.

**Feature:**

1. Cars will be lined up by order of heat finish. The top 3 from the previous feature (not including series events) will be lined up behind the rest of the group of drivers that qualified in the heats, regardless of where they qualified in the heats. Any driver who has not competed in the prior event in the selected division will start at the rear of the feature event, regardless of where they qualified in the heats. Any cars disqualified from the most recent race event will start behind non-previous week cars. Drivers who do not qualify in the heats will start the feature at the rear of all.
2. In the event of a double feature caused by unusual conditions during the previous race meet, those cars and drivers not present at the postponed race meet will start at the rear of the make-up feature.
3. No car will be allowed to compete in more than one heat race under any circumstances. No qualified car will be allowed in any consolation race. (exception to the rule roadrunner to just for fun division)

Example:  
heat qualifiers  
top 3 from previous week  
drivers not present event prior  
non-qualified

**Series Races:**

Series races will be treated as their own entity and will follow the same rules as posted above except the top three from the previous event will NOT be penalized. Any driver who has not competed in the series event prior in the selected division will start at the rear of the feature event, regardless of where they qualified in the heats. Any cars disqualified from the most recent race event will start behind new cars. Drivers who do not qualify in the heats will start the feature at the rear of the lineup.

Drivers that participate in Series races will receive 25 regular season points per series race participating in.

## **General Rules**

Anyone who performs an act or participates in actions deemed by Speedway 95 Authorized representative to be detrimental to the sport or to Speedway 95 including, but not limited to verbal abuse of any Speedway 95 official, the consumption of or being under the influence of alcoholic beverages in the pit area during a race meet, the use of or being under the influence of drugs in the pit area during a race meet, fighting - which is defined as making or attempting to make physical contact or reckless operation of a race car or other vehicle in the pit area shall be disciplined appropriately by track management. Any person entering another pit area and causing conflict will be disciplined accordingly. Anyone who has signs of alcohol and/or drug use about their person will be asked to leave the premises. Any person using foul or abusive language toward any track official will be expelled without a refund.

Once a race vehicle is in the race arena, which includes the track, track shoulders, embankments or infield, and regardless of whether the racing action has been slowed or stopped, no driver shall exit his or her vehicle under any circumstances until authorized to do so by track officials or safety crew. The only exception to this rule is if the driver is in immediate danger from fire, hot fluids or other significant threat to his or her safety or well-being. Any driver disregarding this rule will subject to immediate suspended or other penalty imposed by track management.

## PIT RULES

1. All persons in the pit area are under the control of the Pit Steward. Disobedience of the Pit Steward's directives is cause for expulsion from Speedway 95 property. **Speed limit in the pit area is 5 mph for all vehicles.** Any speeding, pin wheeling or other such reckless conduct with any vehicle in the pit area will not be tolerated.
2. Everyone in the pit area must sign in at the pit gate and pay full admission price. Anyone under the age of 18, here after referred to as minors, must present a properly completed Speedway 95 Minor Release Form for the current year to the pit ticket takers and proof of paid admission before entering the pit.
3. Any driver (other than Stars of Tomorrow drivers) that is under the age 18 of must have a valid and legal learners permit or driver's license. Any minor that is interested in racing must be approved by management. Do not assume because you want to race that you can. ALL minor drivers must be accompanied in the pit area by a legal parent.
4. Only vehicles towing a stock car are allowed in the pit area. Personal Vehicles are NOT covered by any insurance in Restricted Areas. There will be a \$20 deposit on any vehicle that is not a tow vehicle and is dropping off picking up parts, fuel, tires etc. . . the driver will have 20 minutes to complete said chore and remove the vehicle from the pit area or they will forfeit the \$20 deposit.
5. Any person who has signs of liquor, drugs or firearms about him/her during a race meet shall be removed from the premises for the remainder of the meet and shall forfeit all doctor's and hospital fees for any injuries sustained during the race meet at which the offense occurred. The vehicle on either side of the Offending party may also be asked to vacate the premises.
6. No racecar will carry more than one person at any time while it is in motion in the pit area or on the track. The only exception is during "Ride with your favorite driver" while vehicle is on the racetrack.
7. No driver, owner, or mechanic will have any claim for damages, expenses or otherwise against track officials, owners, operators or promoters for disqualification, damage to car or driver, and agree that all conditions are safe when they participate in a meet.

8. If you are involved in an accident involving an injury to yourself, advise the tower or pit gate immediately so that the necessary insurance reporting will be accomplished. Any person who refuses or does not seek medical treatment by the official medical team at the track forfeits any and all insurance protection.
9. PIT TOWER ATTENDANT MUST BE NOTIFIED OF ANY CHANGE IN DRIVERS DURING A RACE MEET AND MUST BE NOTIFIED OF SAID CHANGE PRIOR TO THE RACE MEET. If this is not done prior to the running of the race, the driver/owner shall forfeit all purse, points, and position for the race in which the offense took place. Offending cars and/or drivers will be barred from the next meet. There will be no exceptions to this rule. If a car is disabled, the driver is eligible to borrow a different car registered to race in the same division. Pit Tower Attendant must be notified of the change as noted above. If the borrowed car is determined to be illegal at the conclusion of the race, the driver borrowing the car and competing with it will lose any points or purse for that race meet only.
10. Management will review all disputes and infractions and reserves the right to decide on any disciplinary actions to be taken. Decisions will be made, and the offending parties notified prior to the next regularly scheduled meet.
11. Any incident not covered by these rules may be decided upon by management and made a rule for the rest of the season.
12. Disposal of tires and oil is the responsibility of the driver. Waste oil barrels are provided in the tech area.

Speed limit in the pit is 5 M.P.H. for all vehicles. One warning, any repeat offenders will be penalized. First warning will be announced over the PA system. Subsequent offences will be verbally from a track employee or subcontractor.

Any cars left at the race track for more than 7 days after conclusion of the racing season will be removed at the car owner's expense.



## Racing Rules

1. Once a car is on the racing surface, it is under the control of the flagman and race director. Any disobedience of their directions or decisions may be cause for disciplinary action.
2. Any car assisted by the wrecker to get going will go to the rear. Officials have the discretion to return a vehicle to its previous position when the vehicle becomes stuck in the sand/grass when avoiding an accident.
3. Any car spinning out by itself causing a restart will be placed at the rear of the line-up at the restart. Cars purposely or intentionally accelerating during a spinout and endangering others in the process are subject to disqualification from that event. Any car spinning out by itself three times in the same race is subject to disqualification from that event.
4. There shall be no restart of an event because of a spinout or accident if, in the flagman's opinion, the track is not blocked and the driver is not injured or in immediate danger.
5. Any car leaving the line-up or going to the pit area must rejoin the field at the rear of the pack. In the event of an accident all unauthorized persons must remain in the pit area. Violation of this rule may cause disqualification of the car and/or driver for the remainder of the event. Owners are responsible for stressing this rule to their crew. "I didn't know" will not be accepted for an excuse - this is for your own safety to allow trained medical personnel unrestricted access to you in the event of an injury.
6. All feature and championship events shall be run the full number of laps regardless of restarts barring unusual conditions such as rain, darkness, or the lateness of the hour. Feature events shortened by unusual conditions will have been completed under green flag conditions. If the event is called while being run under caution, the last full lap scored will be used to determine finishing positions. To be in final results the car must be on the track, others will be scored according to the number of laps they completed. Final results will be determined by track officials.

7. If in the event of an uncontrollable circumstance that a race cannot be completed in full that race will be considered official if the race is past the half way mark. If not past half way then the race will be restarted the following week. Any cars not in attendance at the originally scheduled event will have to start at the rear of the make-up feature.
8. Rough riding, excessive track use and unsportsmanlike conduct of any kind is not permitted. Arguing with track officials and displays of temper with an automobile in front of the grandstand area are prohibited and will be dealt with severely. Drivers and/or crew coming up to the flag stand or scorers tower uninvited onto at any time will be cause for disciplinary action. Complaints from drivers will not be heard in front of grandstand. Any driver with a problem will proceed to turn 3 where a track official will attempt to resolve the problem. Drivers will disengage from the discussion with the track official when told to do so or be subject to disqualification from the event.
9. Entrance from the pit area to the track is on the third turn. Exit from the track to the pit area is on the second turn. Violators are subject to disqualification from an event.
10. Any car on the racing surface, which is deemed by the Race Director or the Flagman to not be competitive, may be asked to leave the racing surface by display of the black flag. If the car can again compete at racing speeds, it will be allowed to re-enter the race at track official's discretion. Cars must be able to maintain a pace of at least 2 seconds off the lead cars time.
11. Pole car has choice of inside pole or outside pole on restarts in both heats and/or features after original lap is completed. If the first lap is not completed, the line-up goes back to a complete and original lineup. If a car or cars cause a caution during the initial start, track officials may use their discretion to put the car or cars responsible to the rear. Pole drivers have the responsibility set the pace for the start or restart. These drivers will not accelerate on starts or restarts until their cars are exiting turn 4 and have passed the white line on the track in turn 4. Any car deemed to

- have jumped a start will be docked two positions at the next caution flag. If no caution flag is waved then the penalty will be assessed at the completion of the event.
12. A driver or car owner may request to meet with any track official at the conclusion of the race meet provided the request is made to the Pit Steward within 15 minutes of the completion of the race in question.
  13. The same car may not be driven in more than one division during the same race meet. No driver may change cars nor may any car change drivers during the running of a particular race.
  14. All cars must be self-starting in the pit area prior to participation in the race meet.
  15. Driver and track personnel shall not attempt to fix any car on the racing surface.
  16. All lapped cars in the feature will go to the rear of the field inside 10 to go.
  17. No cell phones of any kind allowed in the racecars at any time. Anyone caught with a cell phone in their car will be disqualified from that event.
  18. All Late Model, Street and Sport Fours will be required to have transponders. All other divisions will be hand scored. Transponders will be available through Speedway 95 Promotions, Inc. for purchase or to rent on a weekly basis. If you already own a transponder, please record the number on your driver's form when filled out for the season.

# TRANSPONDER MOUNTING INSTRUCTION SHEET

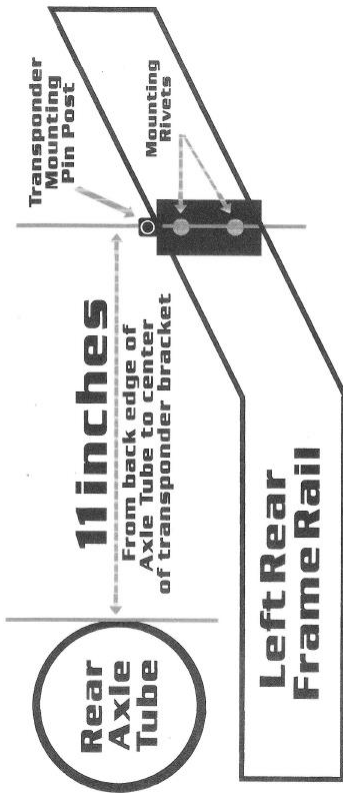

## Flag Rules

### **Green Flag:**

The green flag signals the start or re-start of a race. On an original start, cars must remain in their position until they have crossed the start/ finish line. Any car getting out of line or passing before said start/finish line on the original start of a race will be penalized two positions for each car passed. On restarts, passing is allowed immediately after the green flag is displayed. Passing prior to the display of the green flag will result in a two position per car passed penalty, assessed at the conclusion of the event. All penalties will be assessed at the conclusion or at the next caution after the infraction, whichever occurs first.

### **Yellow Flag:**

The yellow flag signals caution. When the yellow flag is displayed, all cars must stop racing immediately and fall into single file in the position they were in when the flag was displayed. Cars should circle the track slowly until notified by track officials of any change in position. The flagman will notify scoring regarding the reason for the yellow and which car(s) caused the yellow flag to be thrown. These cars will be sent to the rear of the line-up. Cars will be lined up for the restart according to their scored position on the last completed green flag lap, except for those cars designated to go to the rear of the lineup. A lap is considered completed when all cars competing on said lap have crossed the start finish line. Any car going to the pit area while under caution will restart at the rear of the line-up. We do not race to the yellow flag. In the event of a yellow on the final lap all cars must maintain their running position and safely cross the line. The running order will be (frozen) at the time of the yellow flag and the race will be considered complete.

### **Red Flag:**

The red flag means the race must be stopped immediately regardless of the cars position on the track. Red flag laps are not scored. After stopping, wait for the light to return to yellow or for the flagman to signal that it is safe to move. Cars should proceed to turn three and wait for a line-up.

**White Flag:**

The white flag signals that a driver is entering the final lap of a race. The next flag will be the checkered flag unless a red flag is displayed because of an unsafe condition between the cars racing the final lap and the start/finish line.

**Checkered Flag:**

The checkered flag means the race event is over. The first three cars, as determined by distance run, should proceed back to the start finish line for verification. Once released by the officials on the track, the first three cars must proceed directly to the technical inspection garage before returning to their pit areas. Failure to do so may result in disqualification and loss of purse and points for that meet.

**Black Flag:**

The black flag is the consultation flag. When the black flag is displayed to a car, the driver must leave the racing surface for the pit area immediately. Scoring will immediately stop scoring the car when the black flag is first shown. The driver will be informed in the pit area of the reason for the black flag.

The black flag may be displayed for an infraction of the rules, in which case the driver is disqualified from further participation in that event only, and loses all points and purse for that event.

If the black flag is displayed for a mechanical problem deemed by track officials to be hazardous to either the driver or other competitors, the car will be allowed to re-enter the event if the car is repaired. No purse or points will be withheld from a driver black flagged for mechanical problems.

**Passing flag (blue flag with diagonal yellow stripe):**

Shown to a driver who is about to be put a lap down by the leaders. Informs a driver that a faster car is approaching and that the driver should move aside to allow one or more faster cars to pass.

**Half way:**

Will be shown with the yellow and passing flags crossed in an x

## Safety Rules

1. **Batteries:** Battery must be mounted within the car and must be securely bolted to the floor, mounted in a battery box and covered to prevent spillage. Batteries and fuel cells cannot be mounted in the same compartment. (Bombers excluded from this rule)
2. **Fire Extinguisher:** All cars in all divisions must carry an operative 3# minimum fire extinguisher with gauge that is within reach of the driver. All extinguishers must have a metal quick release-mounting bracket. No plastic brackets, tape, wire or other makeshift devices will be allowed.
3. **Window nets:** Window nets are required in all divisions and must be fastened to the roll cage and must be quick release with a seat belt type fastener. Window nets must be securely fastened at all times when a car is on the racing surface.
4. **Helmets:** All helmets must be of racing or motorcycle type and must be Snell approved. Helmets must be worn at all times when a car is on the racing surface.
5. **Drive shaft:** A drive shaft safety loop or under sling is required within 12" of the front universal joint. The drive shaft must be painted white.
6. **Brakes:** Four wheel brakes in proper working order are mandatory at all times. Brake shoes or pads must be mounted and operating on all four wheels (except Late Model division cars).
7. **Overflow can:** A four (4) quart minimum overflow can connected by hose to the radiator and mounted in the engine compartment is mandatory.
8. **Bumpers:** Bumpers must be welded to the frame for safety and must be stock in appearance. **NO BATTERING RAMS.** Rear bumper/bumper covers strapped to body or frame.
9. **Doors:** All doors must be welded shut.
10. **Fenders:** Fenders may be trimmed for tire clearance only. All trimmed edges must be rolled to eliminate rough edges.
11. **Hood:** Hood and trunk must be securely fastened down at all times. Enforcement of this rule is at the discretion of the flagman/race director, and his decision is final.

12. **Firewall:** All cars must have a steel firewall of at least .22 gauge thickness between the engine compartment and the passenger compartment as well as between the passenger compartment and the trunk area containing the fuel cell.
13. **Fuel Cell:** All cars must have a fuel cell with foam inside mounted in a box of no less than .22 gauge steel. All fuel cells must be securely fastened to the vehicle in the trunk area and have a minimum of 8" ground clearance. Fuel cells must have a vent hose with check valve. Vent hose must extend below fuel cell when car is in the upright position.
14. **Glass:** A full windshield of either safety glass or Lexan™ is required in all divisions. If a windshield is lost during a race meet, the driver may continue to race if he wears goggles or a full face shield and installs at least 1/4" mesh screen over the windshield area. Cracked or broken windshields must be cleared by the Safety Committee before a car will be allowed to compete.
15. **Steering Column:** Steering columns must be collapsible or have at least two (2) universal joints. Steering box "rag" joint and heim joints supporting steering column are not considered universal joints. Center of steering wheel must be padded. **All divisions must have quick disconnect steering wheels.**
16. **Roll Cage:** A full roll cage of four uprights joined at the top by a complete loop is required for all divisions. Front hoop and supporting bracing is mandatory. Front hoop is optional in Strictly Street Division. All piping must be at least 1 1/2" O.D. steel and welded 360 degrees. No galvanized pipe allowed. No threaded fittings or flattened ends will be allowed. Three (3) door bars on driver's side are mandatory, with proper bracing and gussets. Two (2) door bars with proper bracing and gussets are required on the "Passenger" side, with three strongly recommended. These bars may either follow the contour of the door or be square with front and rear uprights. A complete hoop is required overhead with at least one bar either diagonally across or front to rear. At least two braces must extend behind the rear uprights to a point on the frame at least three feet back. Bracing



extending into the trunk area to protect the fuel cell is recommended. A horizontal bar between the two front uprights in the dashboard area is recommended. A driver side vertical "vent window" brace is recommended. A plate of at least 1/8" thickness is required to be welded and gusseted between the door bars and the body panel on the driver's side. The plate should be located so as to protect the driver from foreign objects that may pierce body panel.

17. **Seats and seat belts:** aluminum seats are recommended in all divisions. If the fiberglass seat is used, it must be installed with mounting bolts reinforced with 1/8" x 3" x 6" plate both on the bottom mounting points and the back mounting points. Seats must be mounted attached to the roll cage. Seat belts must be airplane type quick release and capable of withstanding 3,000# body block test. The seat belts must be attached at two separate points on the roll cage equal distance from the center of the seat back and no less than twelve (12) inches apart. They must be attached with bolts having a minimum diameter of 1/2". Bolts must be aligned so that the direction of stress will be in direct line with the pull of the seat belt. If belts are attached to a steel plate attached to the frame, the plate must be a minimum of 1/4" thick. Shoulder straps are mandatory and must be securely fastened to the roll cage behind the driver's seat or to a 1/4" plate welded to the roll cage behind the driver's seat. Sternum and submarine (crotch) belts are highly recommended. Seat belts and helmets must have a date of manufacture not more than four years old. 5-point safety harness required, harnesses must have a date of manufacture not more than six years old unless approved by Safety Team.
18. **Clothing:** All drivers in all divisions must wear an approved long sleeve fire retardant racing suit at all times when the vehicle is on the racing surface. This includes test and tune sessions. Racing suits must be free of rips, tears and holes, and have a date of

manufacture of not more than four years old, to be checked a few times a year by the safety committee.

19. Any jack points protruding through the body panels must be approved by the Safety Committee. Safety Committee approved 1" rub rails mounted flush with body panels allowed in all divisions.
20. No boxing of the passenger side of the interior will be allowed if it prohibits the easy removal of the driver through the passenger side of the car.
21. All vehicles must have front and rear tow hooks made of 1/2" rolled steel and installed as a vertical loop. Late Model cars may make tow arrangements under the hood or trunk of the car. The track and its tow crews will have no responsibility whatsoever for damage resulting from towing a disabled vehicle from the racing area.
22. The Safety Committee has the right to disqualify any car from competition based on any infraction of the safety rules. Any infractions must be re-inspected before that car will be allowed to compete. The Safety Committee is responsible for the placement and visibility of numbers.
23. No anti-freeze in cooling systems. Water and KEEP KOOL™ quick cool only.
24. Any weight added to vehicles must be lead only and painted white and have the car number on it.

**All Saturday Night drivers must wear Nomex™ racing gloves.  
No Mechanics Gloves allowed.**

## **General Technical Rules**

1. All cars must start the race meet with all body panels in place. Body components found to be illegal must be replaced before that vehicle will be allowed to compete. Removal of an illegal component once the race meet has begun does not make that car legal.
2. No equipment will be considered as having been approved by reason of having passed through inspection undetected. Any equipment which does not meet specifications or tolerances may not be eligible for approval.
3. All cars being weighed for compliance with technical rules will be weighed with each wheel centered on a scale, the driver belted in the seat and sitting in an upright position with his/her helmet on or resting in his/her lap

## Teardowns

1. Management or the Technical Committee may request a technical inspection of any car at any time. Refusal to submit to technical inspection is considered out of stock and will cause loss of purse and all accumulated points. Top three finishers in each feature must go directly from the track to the inspection area. If you go to your pit area first, you will be considered illegal and disqualified. Management reserves the right to exclude anyone from the inspection area at any time. Only those persons approved by the Technical Inspector are allowed in the inspection area.
2. When there is a specific question by other competitors in the same division regarding the legality of a particular part of a particular car, the following procedure must be followed in order to have the Tech Committee inspect that car:
  - a. One driver/car owner competing in the same race meet as the car in question must notify the Pit Steward at least 15 minutes before that race that they desire an inspection of that particular part of that particular car. The driver or owner requesting the inspection must present \$500.00 and a technical inspection request form
  - b. If the car in question is found to be illegal, the money will be returned to the petitioner(s) and the car will be disqualified from the race meet. If the car is found to be legal, the money will go to the owner of the car in question minus the cost of the technical inspection. Only one (1) petitioner will be allowed to observe the inspection.

Drivers of cars found to be illegal following an inspection by the Technical Committee will lose all points accumulated during that race meet. Any purse monies won during the race meet at which the car was found illegal will be forfeited. **Tech has the option to give last place points and loss of award money to a car/driver that has an infraction to the rules that would not warrant a disqualification.**

3. Any car found to be in violation of technical rules may be subject to reinspection before it will be allowed to compete again. For the purpose of rule enforcement, the term "STOCK" will mean of original equipment manufacturer (GM, Ford, Chrysler, etc.) Any aftermarket parts are allowed at the discretion of the Technical Inspector.

## Late Model

**Bodies:** (also see page 29 & 30)

1. Must be stock appearing template type - ABC Specs
2. New 2019 Five Star Late Model bodies is not approved.
3. May be constructed of steel, aluminum or fiberglass. No carbon fiber.
4. Full front and rear windshield constructed of a minimum eighth (1/8) inch Lexan. Windshield must be braced to prevent any deflection and/or distortion at speed.
5. "A" post mounted windows up to fourteen (14) inches long at the top of door and 90° straight.
6. Minimum roof height is forty-seven (47) inches as measured in the center and ten (10) inches rearward of the windshield. Roof may drop one (1) inch back toward the rear windshield.
7. Maximum spoiler size six- and one-half inches x sixty (6½ x 60) inches. Supports or bracing in front of the spoiler will not be allowed.
8. Spoiler must follow contour of the rear trunk lid or body shell with a maximum height of forty-one and one half (41½) inches measured from the ground to the top of the spoiler. No portion of the spoiler at its base may extend beyond the area where it connects with the body or trunk lid.
9. Air flow control devices no higher than two (2) inches may be applied to roof rear window and deck lid.
10. Only one per side and must run parallel to body centerline.
11. Hood and deck lid must be tethered to the roll cage.
12. Lifting/towing chains or cables must be installed both at the front and the rear of the race car are required. Absolutely No Exception.
13. All body measurement will be checked with Five Star Referee.
14. No panning of any kind to underside of car or airflow devices except for what is allowed in the rule book.

**Frames:**

1. Must be square steel tubing a minimum of two (2) inches x three (3) inches.
2. Rear clip to be square tubing only.
3. One-hundred and four (104) inch wheelbase minimum.

**Weight:**

1. All cars being weighed for compliance with technical rules will be weighed with each wheel centered on a scale, the driver belted in the seat and sitting in the upright position with his/her helmet on or resting in his/her lap, with car being race ready, full of fuel.
2. Built engine: 2,750 lbs.
3. GM Crate engine #604 without cam change: 2,700 lbs must run a Speedway 95 approved adapter/restrictor plate. Part Number 1480 supplied by RPM Engines, Georgia VT (802) 524-7406, will be available for purchase at the racetrack.
4. GM Crate engine #602, #603 and #609: crate motors allowed updates per act specs 2,700 lbs.
5. Left side maximum is fifty seven percent (57%) before and after race
6. All ballast weight must be located outside of the driver compartment with each piece attached with a minimum of two (2) three eighths (3/8) inch bolts, washers and locking nuts.
7. All weight must be lead with each piece painted white and display car number.

**Weight Penalties/Allowances:**

1. Any engine with stock clutch assembly.....-50 lbs.
2. Engine set back up to two (2) inches.....+50 lbs.
3. Aluminum body shocks meeting all other requirements  
.....+20 lbs.
4. Koni shock.....-25 lbs.
5. Min weight.....2,650lbs

It is the driver's sole responsibility to know what he/she has for a motor and may be checked at any given time. If motor is checked and illegal it will be at owner's expense if legal is at the track's expense.

**Suspension – Steering:**

1. Any steering system allowed.
2. Any sway bar system allowed.
3. Tubular upper and lower control arms allowed.
4. Any steel body shock allowed with a common retail value not to exceed \$200.00 each. For clarification: One shock and one spring per corner. MUST remain completely unaltered with product number and manufacturer visibly identifiable
5. All shocks subject to claim by Speedway Management two hundred dollars (\$200.00) each at any time.
6. No gas or adjustable shocks except for Koni 30-7436, Koni 30-7499, Koni 30-7325, Koni 30-9325, Koni 30-9436, Koni 30-7647, Koni 30-1309.
7. Bump stops allowed – disc type only
8. No traction control of any kind.
9. No driver-controlled chassis adjustments except for brake bias.
10. Track width not to exceed sixty-six and one half (66½) inches as measured at spindle pin height.
11. There is no ride height rule, but body must meet all ABC specs.  
**No ride height on chassis but min body height from body to ground is 3".**

### **Wheels – Brakes – Tires:**

1. Steel racing wheels up to eight (8) inches wide as measured from inside of bead to bead.
2. Any brake systems allowed. All four wheels must have brakes.
3. Tire pressure bleeders shall be allowed.
4. Speedway 95 Official Track Tire: American Racer 955.26.5 on LEFT SIDE ONLY and American Racer 955.27.0 on RIGHT SIDE ONLY. Tires must be purchased from Speedway 95 track representative. Once tires leave the tire truck, ABSOLUTELY NO RETURNS.
5. Each car must have four registered tires on the car for the heat and the feature. Speedway 95 tech officials shall maintain an inventory of all registered tires for each Late Model team, with all tires registered to the car number. Late Model teams shall be responsible for their own tire management.
6. From May 11<sup>th</sup> to May 18<sup>th</sup> Late Model teams shall have the option to purchase a maximum of six (6) new tires to begin their registered tire inventory for the 2019 racing season. Beginning May 25<sup>th</sup> on actual Late Model racing events thereafter, teams shall have the option to purchase a maximum of one (1) new tire for their registered tire inventory. Purchased tire shall be registered to that team's car number and be mounted on the car and run on the night it was bought on in both the heat and feature. Should the option of one (1) new tire purchase not be exercised, the option is forfeited. All tires shall be registered to the car number.
7. Late Model teams arriving to race after May 18<sup>th</sup> shall have the option to purchase a maximum of four (4) new tires to begin their registered tire inventory and on actual Late Model racing events thereafter, shall have the option of purchasing a maximum of one (1) new tire for their registered tire inventory. Should the option of one (1) new tire purchase not be exercised, the option shall be forfeited. All tires shall be registered to the car number. Purchased tire shall be



registered to that team's car number and be mounted on the car and run on the night it was bought on in both the heat and feature.

8. Should a tire be damaged during a race event, it shall be the responsibility of the race team to present the damaged tire that race meet, and in a timely manner, to Tech for inspection. All tire replacements must have a written record with Tech regarding inspection and approval for replacement. Only tires with 50% or more tread will be eligible for replacement. It is speedways sole discretion on replacement of any damaged tire.
9. Speedway management reserves the right to modify tire rules in conjunction with the division's needs and concerns.
10. Absolutely no tire softener or any chemicals used while mounting tires to rims may be used. Durometer testing shall be done at random. Any tampering with tires will result in disqualification.

#### **LATE MODEL SERIES RACE TIRE RULES:**

Saturday night cars can only purchase 2 tires, purchased tires shall be registered to that team's car number and be mounted on the car and run on the night it was bought on in both the heat and feature. Teams showing up for their first time on a series race can purchase 4 tires.

Series #2 - #4 any team that didn't race Saturday night or Series #1 may purchase four tires, 2 of those tires must be run three (3) heat cycles as prescribed by tech prior to use in qualifying, this car must start at the rear of the feature race. Purchased tires shall be registered to that team's car number and be mounted on the car and run on the night it was bought on in both the heat and feature.

#### **Absolutely no tire softener.**

**If tech suspects tire softener all tires will be dismantled and confiscated, and you will be disqualified. If protested a sample of the tire will be sent out for evaluation. The driver will be responsible for all costs of the testing if it is found positive.**

**All Engine Guidelines:**

1. Gage legal Holley #4412 only.
2. Any non-tapered spacer/adaptor up to one (1) inch thick.
3. Any exhaust system that utilizes an as manufactured muffler(s).
4. No crank trigger ignition system.
5. No electric or belt driven fuel pumps.

**Non-Sealed Engine Guidelines:**

1. GM, Ford, Chrysler small blocks only. Must be cast iron.
2. No portion of piston can protrude above block deck surface.
3. Maximum overbore = .060"
4. Maximum compression ratio = 11:1
5. Stock OE type crankshaft only. OE stroke. (3.480 inch for GM)  
No modifications except as needed for balancing. Exception – Ford 302 based engines may utilize a 3.400 inch stroke crankshaft to attain a displacement of 347 cubic inch.
6. Connecting rods must be magnetic
7. Any flat tappet camshaft. No mushroom lifters. Chain driven only.
8. Stock lifter bore size only.
9. Built engines are required to have cast iron heads only. Maximum valve size = 2.02 intake/ 1.60 exhaust. No port or combustion chamber modifications.
10. Roller rocker arms allowed. 1.5/ 1.6 ratio only. No shaft rockers.
11. Wet sump oiling only. External/remote filters and coolers allowed.
12. GM small port Bowtie Vortec #25534351 allowed in as produced fashion. Ford and Chrysler performance division heads to be determined on a case by case basis.
13. Edelbrock performer intake only. #2101, #2104, #2116 and equivalent for Ford and Chrysler.

**Crate Engine Guidelines:**

Must follow GM Specs or ACT crate motor guidelines

1. GM # 602 allowed
2. GM ZZ-4 based engines – ie # 603 and #609 allowed.

3. Ford # M60075347JR allowed must add 10 lbs per side on front clip as close to upper control arms as possible.
4. All crate engines must have a full seal set provided by the OE manufacturer or Red Line of Hollowell, S&S Performance of Farmingdale and Thayer's Automotive of Hermon.
5. GM # 604 engines without a cam change will be allowed.

#### **Cooling – Battery - Exhaust:**

1. Any radiator that fits under the stock hood is allowed.
2. Water and a cooling additive only. No antifreeze allowed.
3. Must have a minimum one (1) quart capacity sealed overflow container.
4. Car must not have fluid leaks of any kind.
5. Battery must be in a sealed battery box and properly secured.
6. **Exhaust system with muffler is required and must extend past the driver's compartment turning down toward the ground with the exhaust system under the car not out the side of car.**

#### **Drive Train:**

1. Any rearend, may be locked. Rearend safety hubs recommended. No cambered tubes
2. Any OEM three (3) or four (4) speed transmission is allowed.
3. OEM type T-10 is allowed.
4. Must have two (2) forward gears and reverse.
5. No aftermarket transmissions except as noted above.
6. No internal to the transmission clutches.
7. Cluster gear must stay engaged to the main shaft at all times.
8. No straight cut gears allowed.
9. Minimum clutch diameter = 7.250 inches
10. Magnetic flywheel only.
11. Driveshaft must be painted white.
12. Driveshaft loop required near the front of the driveshaft with material specification minimum of one-quarter (1/4) inch x two (2) inches. Rear driveshaft loop is recommended.

**THE TECH COMMITTEE RESERVES THE RIGHT TO ADD OR SUBTRACT WEIGHT AT THEIR DISCRETION FOR EACH ITEM NOT MEETING SPEEDWAY 95 SPECIFICATIONS.**

**Tech has the option to give last place points and loss of award money to a car/driver that has an infraction to the rules that would not warrant a disqualification.**

**THE TECH COMMITTEE MAY ADD OR SUBTRACT WEIGHT IN THE INTEREST OF COMPETITION.**

**Any alteration to any part of the car not specifically covered in these rules must be cleared with the technical inspector or it will be considered illegal. In other words, IF IT DOESN'T SAY YOU CAN DO IT, YOU CAN'T.**

**Any specification not covered by these rules may be decided upon by tech management and made a rule for the rest of the season.**

# ABC Body Dimension Sheet

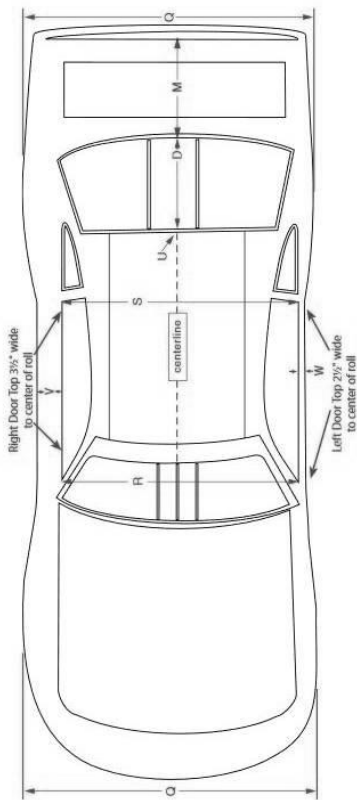
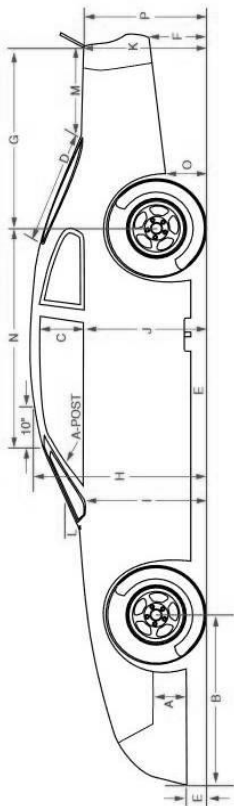

Pictures and dimensions provided courtesy of <https://www.fivestarbodies.com>

## ABC BODY DIMENSIONS

<b>A</b>	<b>NOSE FLAP HEIGHT:</b> from bottom of nose to top of side flap***	13"
<b>B</b>	<b>FRONT OVERHANG (MAX):</b> on centerline	46"
<b>C</b>	<b>SIDE WINDOW OPENING (MIN):</b> at B-post	15"
<b>D</b>	<b>REAR WINDOW LENGTH: on centerline**</b> Five Star bodies	31½"
	AR bodies	31⅛"
<b>E</b>	<b>NOSE/SIDE PANEL CLEARANCE (MIN):</b> from ground	4"
<b>F</b>	<b>BUMPER COVER HEIGHT (MAX):</b> from ground	15"
<b>G</b>	<b>REAR OVERHANG (MAX):</b> from base of spoiler at centerline to axle centerline	47"
<b>H</b>	<b>ROOF HEIGHT (MIN):</b> 10" back from windshield, on centerline	47**
<b>I</b>	<b>FENDER HEIGHT:</b> at rear	32½**
<b>J</b>	<b>DOOR HEIGHT (MIN):</b> at rear	33**
<b>K</b>	<b>QUARTER PANEL HEIGHT:</b> at bumper cover/deck lid intersection (+/-¼")	34½**
<b>L</b>	<b>WINDSHIELD ANGLE:</b> at center/at roof windshield post	26/30°
<b>M</b>	<b>REAR DECK LENGTH (MAX):</b> at center, from base of spoiler to rear window** Five Star bodies	23¾"
	AR bodies	23⅜"
<b>N</b>	<b>FRONT OF ROOF TO CENTER OF REAR AXLE</b>	57½"
<b>O</b>	<b>QUARTER PANEL HEIGHT:</b> at back of wheel well opening	13"
<b>P</b>	<b>BUMPER COVER HEIGHT:</b> at base of spoiler, on centerline	34⅞**
<b>Q</b>	<b>BODY WIDTH (MAX):</b> at wheel wells	79½"
<b>R</b>	<b>DOOR TO DOOR WIDTH (measured through car):</b> at A-posts and inside edges of doors	68"
<b>S</b>	<b>DOOR TO DOOR WIDTH (measured through car):</b> at B-posts and inside edges of doors	67"
<b>U</b>	<b>ROOF HEIGHT, REAR:</b> at centerline	45½"
<b>V</b>	<b>RIGHT DOOR TOP:</b> to center of roll	3½"
<b>W</b>	<b>LEFT DOOR TOP:</b> to center of roll	2½"

\* If Dimensions H, I, J, K or P are higher than the stated dimensions, all five must increase by the same amount.

\*\* Must fit centerline template within allowable tolerance.

\*\*\* 13 inches is the height of the nose flap only. This dimension is not measured from the ground.

Pictures and dimensions provided courtesy of <https://www.fivestarbodies.com>

## Street

**Bodies:** Cars must be American made passenger production six (6) or eight (8) cylinder cars 1970 to present. All chassis must maintain stock wheelbase for frame utilized. Cars must be street legal for make and model. No convertibles, Vans, Station Wagons, or pick-up truck type vehicles, Front or rear wheel drive allowed. No four-wheel drive vehicles. Bodies may be interchanged with chassis, but must be of same make, example, Chevy body on Chevy frame Etc. Stock after-market panels allowed per stock specifications. Must be stock steel and must have a complete Stock Steel Roof. Any car that comes stock from the factory with a fiberglass roof, MUST add 25 lbs. Rest of body must match model of roof, including front fenders, must be stock appearing. only exception is front and rear stock type vehicle plastic bumper covers of any model allowed. No dirt or wedge type bumper covers. Floorboards must be stock on driver's side. Passenger side may be fabricated but must remain fully closed in and of similar height to floorboard. No tunnel or raised tin fabrication. Firewalls may be fabricated from .22 gauge steel but must remain in stock location. Fabricated firewalls receive a 25 lb. weight penalty. Rocker panels may be removed but must be replaced by metal fabrication that keeps interior of car enclosed. Doors may be replaced with .22-gauge steel. Hoods may be replaced with fiberglass or aluminum. Air Breathers cannot protrude outside of hood. Additional hood scoops allowed but only opened in the rear, No Air Induction Scoops ALLOWED. Rear deck lids must be in place and of stock length and installation. Minimum wheelbase of any car 101". Inner body panels may be removed. Spoiler 5" x 60". No side boxing. Spoiler cannot extend past top of bumper cover. Max spoiler height 43" from ground to top of spoiler. Modifications to the rear body is allowed to achieve this height only. No lengthening of tail pieces or fender shelving added, or any other body modifications allowed. Maximum length for any Gen Camaro 37" from axle center to spoiler mount location on rear bumper. Maximum length for Monte Carlo 40"

No panning of any kind to under side of car or airflow devices except for what is allowed in the rule book

All cars must start the race meet with all exterior body panels in place.

### **Vent windows allowed maximum 12” length**

**Frame:** Must have a four-point roll cage but a full roll cage is suggested. Square tubing allowed from center of rear-end back, must be in stock position. Roll cage cannot be set back any closer than 24 inches from center of rear end. **Wheel base must match suspension. All cars must have tow hooks on front and rear.**

**Weight:** Must weigh a minimum of 3,000 lbs. with driver in the car. Maximum Left side weight is 54% (54/46). All cars being weighed for compliance with technical rules will be weighed with each wheel centered on a scale, the driver belted in the seat and sitting in the upright position with his/her helmet on or resting in his/her lap. Any car that comes stock from the factory with a fiberglass roof, **MUST** add 25 lbs.

Fabricated firewalls receive a 25 lb. weight penalty.

**Suspension:** Front and rear adjustable cups allowed. Rear jacking bolts allowed. 4th generation Camaro running coil over struts on car must have spanner nuts and must be doubled up so they are locked. Upper control arms on rear end may be re-drilled. Lower rear control arm mounts may be moved up or down, must remain stock. Stock replacement tubular upper A-frames allowed with a non-adjustable ball joint only, mounted in stock position on stock mounts 1” variance from stock length allowed. Bolt in Ball joints **ONLY**. Lower A-frames must remain stock make and model. Stock sway bars only in stock location, stock frame mounts may be adjustable on one side. Max diameter 1 3/8”. Shocks must be stock replacement over the counter 50/50 shocks or struts and must be mounted in stock location. No high performance, adjustable or “take apart” shocks allowed no split valve shocks. 50/50 means a 5-5 shock not a 7-7 or a 3-3, etc . . . No reinforcement of brackets or suspension arms. Minimum height of any part of the body



or frame must be 5" all. All other suspension parts must be stock for make. Rear leaf spring cars may have adjustable shackles no longer than 6", lowering blocks allowed non-adjustable. Panhard bar and trailing arms allowed on full frame metric cars. Three (3) link rear suspension with stock ends ALLOWED. Non-adjustable MUST be welded solid. No bump stops or suspension limiting devices allowed. Leaf Springs MUST be steel

IF IT COST MORE THAN \$100.00 YOU MUST HAVE IT OK'D  
FIRST.

**Wheels:** May use aftermarket steel wheels. Track width no more than 64 1/2". Max. Maximum wheel width seven (7) inches.

**Tires:** American Racer 7" 225 SH or H track tire. Tires must be purchased from the authorized tire representative. Once Tires leave the truck ABSOLUTELY NO RETURNS. **No chemicals may be used while mounting tires to rims.**

**Absolutely no tire softener.**

**If tech suspects tire softener all tires will be dismounted and confiscated, and you will be disqualified. If protested a sample of the tire will be sent out for evaluation. The driver will be responsible for all costs of the testing if it is found positive.**

**Engines:** 602 crate engines allowed with stock specs. **No rebuilds.**

GM max engine size 350 plus .060 over . Ford max 351w plus .060 over Chrysler 360 plus .060 over. Engine block cylinder heads must be cast iron and O.E.M. stock. Crank shaft must be cast or forged. No modifications or lightening. **Minimum** two valve relief pistons allowed. Stock steel connecting rods aftermarket stock replacement. Racing oil pan allowed. Cam shaft must be hydraulic flat tappet only. Stock lifter bore. Max. lift 450 at the valve. Stock type rockers **1.5 Ratio**. Cylinder heads must be O.E.M. castings straight plug. World product head #4361 will be allowed. Vortex heads allowed. Max valve size 1.94 intake 1.6 exhaust. Intake must be stock O.E.M. cast iron 2 barrel or 2101 or 2116 aluminum **ONLY** may be used. Max compression 10.2:1.

**Carburetors:** Stock Holly™ 4412. No VDL's. No changeable air bleeds. Only modifications are the removal of choke plate assembly, jet change, power valve change and accelerator pump change. Rochester™ (2) two barrel allowed. Must use Mr. Gasket™ # 1929, #1937 or #1933 adapter **ONLY**.

**Fuel Cells:** May be mounted through trunk floor and securely fastened to the car. Fuel Cell minimum ride height 12" from the ground. No adjustable or sliding spacers.

**Exhaust:** Racing mufflers mandatory. If the track deems your race car to be too loud, you will be required to run track muffler.  
1 5/8" maximum underslung headers allowed stock manifolds no ram horn manifolds.

**Glass:** All window glass (except for windshield) must be removed. All broken glass must be removed from the car before it will be allowed to compete. Quarter panel windows of clear Lexan construction are permitted. No deflectors, or boxing of door opening area is permitted only Vent windows allowed maximum 12" length

**Transmission:** Stock cast iron 3 speed. All gears must be working. Stock steel fly wheel **Minimum 16 lbs** and stock clutch. Automatic transmissions allowed. Stock torque converters only.

**Rear End:** Locked rear ends allowed. Mini spool or welded. NO RACING BRACKETS ALLOWED. No cambered rear ends. 5:88 final drive ratio. Stock for make. 9" Ford allowed, no floaters.

**Radiator:** No anti-freeze allowed. Water and Keep Kool™ only. All cars must have an overflow jug in working order.

**Battery:** Battery may be moved to behind the driver's seat or remain in stock location

**Brakes:** All cars must have four-wheel brakes in working condition. Four wheel disc brakes allowed no clamp on brackets. Stock Calipers. After market pedals and master cylinders allowed. No brake bias mechanisms allowed.

**IF IT COST MORE THAN \$100.00 YOU MUST HAVE IT OK'D FIRST.**

**THE TECH COMMITTEE RESERVES THE RIGHT TO ADD OR SUBTRACT WEIGHT AT THEIR DISCRETION FOR EACH ITEM NOT MEETING SPEEDWAY 95 SPECIFICATIONS.**

**Tech has the option to give last place points and loss of award money to a car/driver that has an infraction to the rules that would not warrant a disqualification.**

**THE TECH COMMITTEE MAY ADD OR SUBTRACT WEIGHT IN THE FAIRNESS OF COMPETITION**

**Any alteration to any part of the car not specifically covered in these rules must be cleared with the technical inspector or it will be considered illegal. In other words, IF IT DOESN'T SAY YOU CAN DO IT, YOU CAN'T.**

**Any specification not covered by these rules may be decided upon by tech management and made a rule for the rest of the season.**

**Motorsports at all levels pose a risk to your wellbeing. Following the rules set for by Speedway 95 in no way guarantees or suggests your safety.**

## Sport Four

**Tube Chassis:** Tube chassis must be rear wheel drive only.

**Floor Pan Car:** Must utilize the majority of OE/as produced vehicle structure. Outside of the main roll cage structure a basic front and rear hoop for crash & component protection is allowed.

**Bodies:** Must resemble a stock body automobile in regard to size, shape, and contour.

Aluminum and Fiberglass bodies allowed and must add twenty five (25) pounds. Hood and deck lids must have all bracing removed and be tethered to the car.

Sun roof must be covered with sheet steel of similar thickness to existing roof structure and welded into place. No "T" tops. Original equipment windshield (safety glass) in good condition may be used. Minimum eighth (1/8) inch Lexan windshield is allowed with at least one (1) support strap installed close to center. All other glass and combustible material must be completely removed.

One (1) inside mirror no larger than three (3) inches x twelve (12) inches and one (1) left side mounted mirror no larger than five (5) inches x five (5) inches is allowed.

Spoilers may be a maximum of five (5) inches tall and fifty-eight (58) inches wide.

Bumpers are required to have a retention chain/cable at both ends. Rub rails mounted tight against the body are allowed.

Lifting/towing chains or cables must be installed both at the front and the rear of the race car are required. Absolutely No Exception.

No down force bodies or wedge noses. Back end of body must be enclosed. No open tails.

### **Eligible models:**

1. Any mass produced [4] cylinder passenger cars.
2. Two or four door models permitted. No convertibles, minivans, or trucks.
3. Front engines only.
4. No all wheel drives, all wheel conversions or 4x4 will be allowed.

**Frame:** Any tube or stock type chassis shall be allowed. Tube chassis rear wheel drive only. No front wheel drive tube chassis allowed.

Pipes must be a minimum of one and one half (1½) inch x point zero nine five (.095) inch wall.

Frame tubing must a minimum of two (2) inch x two (2) inch x point one two five (.125) inch wall. Fabricated tube chassis wheelbase minimum ninety six (96) inches.

**Weight:** One (1) pound/cc with a twenty-two hundred (2200) pound minimum for fuel injected cars.

One (1) pound/cc with a twenty-one hundred (2100) pound minimum if under twenty-three hundred (2300) cc and carbureted.

Left side maximum is fifty-six percent (56%).

All ballast weight must be located outside of the driver compartment with each piece attached with a minimum of two (2) three eighths (3/8) inch bolts, washers and locking nuts.

All weight must be lead with each piece painted white and display car number.

All cars being weighed for compliance with technical rules will be weighed with each wheel centered on a scale, the driver belted in the seat and sitting in the upright position with his/her helmet on or resting in his/her lap.

### **Weight Penalties/Allowances**

Non-steel body.....+25 lbs.

Full tube chassis/no O.E. floor pan.....+50 lbs.

Double overhead cams.....+50 lbs.

Variable cam timing.....+50 lbs.

7" wheels.....- 50lbs.

Longitudinal engine w/iron head.....-100 lbs.

Longitudinal engine w/aluminum head.....-50 lbs.

Tube chassis cars with longitudinal engine placement will receive no weight break.

### **WHEELS – BRAKES – TIRES**

American Racer 13” or 14” Track tire or any radial tire no less than 60 series. No mixing of tires. Car must have all four racing tires or all four

DOT tires. All tires on car must be same size, either all 13" or all 14". Track tires must be purchased from the authorized Speedway 95 tire representative. Buffing Allowed. Absolutely no tire softener. **No chemicals may be used while mounting tires to rims.** Any steel wheels 7" or 8" width to maintain 64" track width. Spacers allowed. Steel wheels required for all cars. Every wheel must have all wheel studs with required one (1) inch lug nuts. All four wheels must have brakes in good condition. Brakes must be OEM or OEM replacement type. Cars may be converted to rear disk brakes using production model parts from any make or model. Aftermarket brake pedal assemblies allowed. All tires must be the same size and style – no mixing tire brands or styles. Slicks will not be allowed. Commonly available DOT treaded tire seven (7) inches maximum or Speedway 95 Official Track Tire  
7" Wheels 50lbs break

**Durometer testing will be done**

**Once Tires leave the truck ABSOLUTELY NO RETURNS**

**Absolutely no tire softener.**

**If tech suspects tire softener all tires will be dismantled and confiscated, and you will be disqualified. If protested a sample of the tire will be sent out for evaluation. The driver will be responsible for all costs of the testing if it is found positive.**

**Engine Specifications:** Twenty five hundred (2500) cc maximum.

.04 maximum overbore will be allowed.

Expanded/Racing oil pans will be allowed.

Dry sump pumps will not be allowed.

After market pulleys will be allowed.

Aftermarket heads will not be allowed.

Roller valve train parts allowed only if OEM parts. No aftermarket.  
Maximum 480 lift camshaft All pistons will be allowed.

Connecting rods must be steel.

Variable valve timing will be allowed.

Knife edging cranks will not be allowed.

Maximum compression ratio is 12:1

Engine must be of same manufacture as chassis. Honda for Honda,  
Toyota for Toyota etc. Engine must fit chassis with no modification of  
motor mounts.

**COOLING/BATTERY/EXHAUST:** Any radiator that fits under the hood  
is allowed.

Water and a cooling additive only. No antifreeze allowed.

Must have a minimum one (1) quart capacity sealed overflow  
container.

Car must not have fluid leaks of any kind.

No forced air induction (turbocharger/supercharger) allowed.

Battery may be relocated. Battery must be in a sealed battery box and  
properly secured.

Exhaust system with a muffler is required and must extend past the  
drivers compartment turning down toward the ground with the end of  
exhaust system under the race car, not out the side or the rear of the  
race car.

No anti-freeze allowed. Water and Keep Kool™ only. All cars must  
have an overflow jug in working order.

**IGNITION:** Any stock ignition or MSD will be allowed.

**Fuel System:**

A fuel cell is mandatory. Maximum twelve (12) gallon fuel cell, in a  
steel container with a check/rollover valve in the vent line; secured  
with two (2) straps front to rear and two (2) straps left to right. The  
minimum dimension of strap material is eighth (1/8) inch x one and  
one half (1½) inch.

All fuel filters must be of metal construction. No plastic, glass or other  
material will be allowed.

Any line containing a combustible material must be metal and routed outside of the driver compartment. Electric fuel pumps must be wired through a low oil pressure cut off switch.

Fuel Cell minimum ride height 8" from ground.

**Transmission:** Transmission/Trans Axle must be stock production for make and model of car.

Car must have functional reverse gear.

Driveshaft must be steel and painted white.

Driveshaft loop required near the front of the driveshaft with material specification minimum of one-quarter (1/4) inch x two (2) inches. Rear driveshaft loop is recommended. Differential/Trans Axle may be locked.

Single disc clutch only. Any flywheel allowed.

**Suspension:** Four (4) inch minimum ride height.

Track Width shall be sixty-four (64) inches maximum measuring from center to center.

All springs will be allowed.

Wedge adjusters will be allowed.

All sway bars will be allowed.

Shocks must be steel, smooth body, sealed, and non-adjustable/rebuildable. Maximum cost \$100.00 per shock or strut. 50/50 shocks only.

Shocks subject to tech testing at any time.

After market suspension parts will be allowed.

Traction Control will not be allowed.

No Bump stops allowed.

**Windshield:** Windshield may be replaced with plastic or Lexan™.

Complete windshield opening must be covered. No other glass allowed.

**Brakes:** Four wheel brakes in proper working order are mandatory. Brake system must remain stock for make and model.



**Anything not covered by any rules for this division shall remain stock as made by the manufacturer. Stock for year and make must apply in all cases.**

**THE TECH COMMITTEE RESERVES THE RIGHT TO ADD OR SUBTRACT WEIGHT AT THEIR DISCRETION**

**FOR EACH ITEM NOT MEETING SPEEDWAY 95 SPECIFICATIONS.**

**THE TECH COMMITTEE MAY ADD OR SUBTRACT WEIGHT IN THE FAIRNESS OF COMPETITION**

**Tech has the option to give last place points and loss of award money to a car/driver that has an infraction to the rules that would not warrant a disqualification.**

**Any alteration to any part of the car not specifically covered in these rules must be cleared with the technical inspector or it will be considered illegal. In other words, IF IT DOESN'T SAY YOU CAN DO IT, YOU CAN'T.**

**Any specification not covered by these rules may be decided upon by tech management and made a rule for the rest of the season.**

**Motorsports at all levels pose a risk to your wellbeing. Following the rules set for by Speedway 95 in no way guarantees or suggests your safety.**

## CageRunner

Vehicles must be street legal for make and model except for modifications made for racing allowed by these rules. Passenger vehicles only. No convertibles, Full size vans, Full Size trucks, Chrysler Imperials, station wagon or full frame Oldsmobile Toronados. No leaf spring vehicles. No ALL wheel drive cars. **No turbochargers.**

Vehicles must be street legal for make and model, except for modifications made for racing allowed by these rules.

**Clothing:** All drivers in all divisions must wear an approved long sleeve fire retardant racing suit at all times when the vehicle is on the racing surface. This includes test and tune sessions. Racing suits must be free of rips, tears and holes, and have a date of manufacture of not more than four years old, to be checked a few times a year by the safety committee. **Fireproof racing suits and racing gloves are MANDATORY.**

**Exterior:** Doors are required to be Welded Shut from the Exterior. Exterior Piping Required as specified on diagram on page 48. All hubcaps must be removed

### **Vehicle must start the event with all body parts**

May remove flammable materials, but dash must stay intact

**Windshield:** Front windshield must be in place when racing. Windshield must be stock glass or Lexan™. All other glass i.e. headlights and marker lights must be removed from the vehicle before it will be allowed to compete. **Window Nets Mandatory**

**Fire Extinguishers:** Operative 3# fire extinguisher with gauge mounted in a metal bracket within reach of the driver is required.

**Tires and Wheels:**  $\frac{3}{4}$ " wheel tilt on right front. Wheel size must be stock for vehicle. **All wheels on car must have the same offset, no mixing and matching offsets.** All wheel studs and lug nuts must be in place. No directional tires. No recaps All tires on the vehicle must be the stock for the Make/Model of the car and same

size/series tires all the way around, 2-4 ply only. No liquid filled.  
**No tire buffing allowed.**

**Suspension:** No cutting of suspension. Slotting of the upper strut towers allowed – straight in only. Stock unaltered.

**Seat:** All stock seats must be fastened in a stationary, upright position. Racing seat may be used with approved bracing.

**Seat Belts:** Racing harnesses **Required** and must be in good condition

**Helmet:** All drivers must wear a DOT approved helmet

### **Must keep Stock Exhaust**

**Battery must be in stock location and securely fastened.**

**Roll Cage: An X-Hoop with two door bars see page 41 or a four point roll cage see page 42 is mandatory in Caged RoadRunner Division.** A roll cage must consist of four uprights joined together at all four corners at the top. Tubing must be at least 1 ½” Round O.D. and minimum .090 wall thickness. All roll cages must be professionally welded. An “X” must be placed between the rear uprights, or a horizontal bar may be used to join the two rear uprights at the bottom, with a diagonal bar joining the top and bottom horizontal bars.

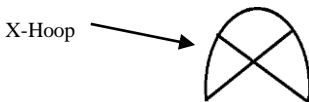

1. Four bars running between front and rear uprights are required on the driver's side. These bars must be padded.
2. A minimum of three horizontal bars or an "x" is required on the passenger side of the vehicle.
3. A horizontal bar between the two front uprights just above or below the dashboard is required.
4. Forward or rearward bars attached to the main uprights are NOT allowed.
5. The roll cage may not reinforce the body or frame or alter the geometry of the vehicle.
6. Roll bars may NOT extend through firewalls.
7. All vehicles with frames must have the roll cage welded directly to the frame NOT the floorboards.
8. All vehicles without frames must use the sandwich method shown in the roll cage diagram to secure the roll cage to the vehicle.
9. May have rearward bars no further than firewall or center of strut towers

All cars must have tow hooks on front and rear.

Motorsports at all levels pose a risk to your wellbeing. Following the rules set for by Speedway 95 in no way guarantees or suggests your safety.

## RoadRunner Racing Rules

A red flag will be displayed in emergency situations. Yellow flags will not be used. If a red flag is displayed prior to the completion of the first lap, all vehicles will be lined up in their original positions. On red flag stops, the vehicles will come to an immediate stop as safely as possible. When the green is thrown after the "Red Flag Stop" the cars will start from where they stopped. Penalties will be assessed for vehicles moving during red flag. Any vehicle leaving the track during a red flag will remain in the pit for the remainder of that race. No passing on the original green until your vehicle has passed the start/finish line. On restarts, passing may be done anytime after the green flag is thrown. The first vehicle to complete the required number of laps under the green flag is the winner. Vehicles that are disabled but, in the race director's opinion, are not in danger or posing a risk to other vehicles, will be left sitting where they are until the end of the race or a red flag is thrown, at which time they may be assisted to the pit area. All pit stops must be made in a safe and orderly manner, at a maximum speed of 5 M.P.H. in the pit area. Loss of a wheel or tire requires immediate exiting of the race track. Failure to do so will result in a disqualification. Vehicles may return to the race when repairs are completed. Return to the track at the direction of race officials posted at the entrance of the track on turn three.

Any discrepancies on the track must be dealt with in the pit.

**Radiator:** No Anti-Freeze allowed. KEEP KOOL™ or water only. Vehicles must have an overflow jug in working order.

**All vehicles must have front and rear tow hooks made of 1/2" rolled steel and installed as a vertical loop.**

**All cars must have tow hooks on front and rear.**

**No Tow hooks means no racing.**

**No Chains & No Straps around the bumper.**

## Modified Enduro Rules

Vehicles must be street legal for make and model except for modifications made for racing allowed by these rules. Passenger car vehicles only. No convertibles, vans or trucks. No leaf spring vehicles. No All Wheel Drives. **No superchargers.**

**Engines:** 4 or 6 cylinder engines only. Any stock engine over 150 hp will not be allowed

**Wheel & Tires:** Wheel size must be stock for vehicle. Maximum 7" wheel.

All wheel studs and lug nuts must be in place. **NO RACING**

**WHEELS.** Stock steel/or aluminum wheels only All wheels on the vehicle must be the same size and made of the same material,

**Aftermarket steel wheels allowed, must be same width and offset as stock.** Tires may vary by one size side to side, for example: 175 on left and 185 on the right, but both tires on each side must be the same size. No directional tires. No recaps, 2-4 ply only. No liquid filled. AIR ONLY. Maximum allowable tread width of tires is 7".

**Tires must have minimum 380 tread wear**

**Buffing is allowed. No tire softener allowed.**

**Bumpers:** Bumpers must be at stock height for make and model of vehicle.

A bumper may be fabricated from thin wall square tubing, but must mount to stock mounts or to round tubing slipped over and bolted to stock mounts. All vehicles must have bumper covers to start the race. Rear bumper/bumper covers should be strapped to body or frame to eliminate dragging. Modified Enduro can run after market front and rear bumper covers, but must have stock bumper or replacement as noted above under it. Bumper covers must match make of car. A protection loop in front of the radiator may be added to the bumper, with one brace on each side attaching to the frame just in front of the radiator.

**Weight:** Left side weight rule 53% of total weight maximum.

**No adding weight**

**Windshield:** Front windshield must be in place when racing. Windshield must be stock glass or Lexan™. All other glass i.e. headlights and marker lights must be removed from the vehicle before it will be allowed to compete. Rear side windows may be replaced with Lexan or sheet metal.

**Body/Frame:** All doors must be welded shut. No body alterations allowed **EXCEPT AS NOTED IN THIS SECTION**. All floor carpets and seats must be removed. Roll bar or four-point cage with door bars is **REQUIRED**. Dashboard may be removed for installation of roll cage only. Steering column must remain stock. Back of rear seat **MUST** be replaced with sheet metal. Fenders may be trimmed one (1) inch for tire clearance. No gutting of the interior metal except for installation of roll cage. No gutting of hoods, trunks or inner fenders. Hood and trunk lids must be on hinges. Tech will determine if too much has been removed and may require re-installation. Interior door panels may be removed for door bar and safety plate installation only. If an interior door panel is removed, there must be bars in that area that are attached to the roll cage.

**No fiberglass body panels allowed**

If driver's doorplate is installed, it must be padded. .22 gauge Steel may be used to replace doors, as long as door appearance remains stock and stock door contours are followed.

**Lexan Rub Rails Allowed**

**Seat:** Aluminum racing seat required

**Seat Belts:** Racing harness must be used and must be approved by Safety Team.

**Helmet:** All drivers must wear a DOT approved helmet.

**Racing Suit: Fireproof racing suits and racing gloves are MANDATORY.**

**Battery:** Batteries **MUST** be placed in rear seat area in a box completely covering the battery.

**Brakes:** All vehicles must have four-wheel brakes in proper working order, **NO EXCEPTIONS.**

**Suspension: 2" maximum tire tilt on left and right front allowed.** One spring rubber allowed per car. No rear wheel tilt. No cambered rear ends. No lowering of the body on the frame. Left side ride height must be a minimum of 5 ½" and Right side must be a minimum of 6". Stock springs may be cut to achieve frame height. Springs must be same size wire. Sway-bar arrangement must be the same on both sides - stock length, with stock parts. No adjustable shocks, no racing springs, no adjustable cups. Stock style upper control arm replacements may be used. No angle type or offset type can be used. Ball joints must be welded to control arm.

**All stock bump stops must be removed**

**Gears/Transmission:** All running gears must remain completely stock for model and generation of vehicle. No 2 speed automatics.

**Rear End:** Open rear ends only. **NO LOCKED REARENDS. NO LOCKED FRONT ENDS.** No posi-trac. **Mufflers are mandatory.**

**Fire Extinguishers:** All vehicles must have an operative working 3# fire Extinguisher with gauge and mounted in a metal bracket within reach of the driver.

**Window Nets:** Window nets are mandatory with a working seat belt type hook.

**Radiator:** No Anti-Freeze allowed. KEEP KOOL™ or water only. Vehicles must have an overflow jug in working order.

**Tow Hooks: ALL CARS MUST HAVE FRONT AND REAR TOW HOOKS OR CHAINS EASILY ACCESSIBLE TO WRECKER CREWS. No Tow hooks means no racing.**

The track and its tow crews will have no responsibility whatsoever for damage resulting from towing a disabled vehicle from the racing area.

**Fuel Tanks:** Fuel cells and fuel tanks must be securely mounted in the trunk area. No cutting of trunk floor to lower fuel cell/tank in car. Boat



Tanks must be in a canister of no less than .22-gauge steel. May have a loop to protect fuel cell, plated and welded to trunk floor.

**A four-point roll cage is mandatory as explained/diagramed on page 20**  
**Anything not covered by any rules for this division shall remain stock as made by the manufacturer. Stock for year, make or generation” of car must apply in all cases.**

**THE TECH COMMITTEE RESERVES THE RIGHT TO ADD OR SUBTRACT WEIGHT OR TO RESTRICT AIR FLOW TO THE ENGINE AT THEIR DISCRETION**

**Tech has the option to give last place points and loss of award money to a car/driver that has an infraction to the rules that would not warrant a disqualification.**

**Any alteration to any part of the car not specifically covered in these rules must be cleared with the technical inspector or it will be considered illegal. In other words, IF IT DOESN'T SAY YOU CAN DO IT, YOU CAN'T.**

**Any specification not covered by these rules may be decided upon by tech/ management, and made a rule for the rest of the season.**

**Disclaimer:**

**Motorsports at all levels pose a risk to your wellbeing. Following the rules set for by Speedway 95 in no way guarantees or suggests your safety.**

## RoadRunners

Vehicles must be street legal for make and model except for modifications made for racing allowed by these rules. Passenger vehicles only. No convertibles, Full size vans, Full Size trucks, Chrysler Imperials, station wagon or full frame Oldsmobile Toronados. No leaf spring vehicles. No ALL wheel drive cars. **No turbochargers, No superchargers.**

**Exterior:** Doors are required to be Welded Shut from the Exterior. Exterior Piping must be bolted required as specified on diagram on page 17. One bar must extend from front fender to rear door, top bar must be lower than the top of the fender. bottom bar must be separated from top bar. No exception, not bolted no racing. See page 57  
2 – 2” steel pipes or tubes on driver’s side required - passenger side door optional. All hubcaps must be removed.

**Vehicle must start the event with all body parts**

**No gutting of interior, except for roof liner and carpet may be removed.**

**Windshield:** Front windshield must be in place when racing. Windshield must be stock glass or Lexan™. All other glass i.e. headlights and marker lights must be removed from the vehicle before it will be allowed to compete. **No lights of any kinds will be allowed at any time.** Window Nets Mandatory

**Fire Extinguishers:** Operative 3# fire extinguisher with gauge mounted in a metal bracket within reach of the driver is required.

**Tires and Wheels:** Wheel size must be stock for vehicle either **steel or aluminum, no mixing.** All wheel studs and lug nuts must be in place. No directional tires. No recaps All tires on the vehicle must be the stock for the Make/Model of the car and same size/series tires all the way around, 2-4 ply only. No liquid filled. **All hubcaps must be removed.**

**Seat:** All stock seats must be fastened in a stationary, upright position. Racing seat may be used with approved bracing. A hoop may be installed in car behind driver to protect driver from roof collapse. No bars extending from hoop to rear of front of car.

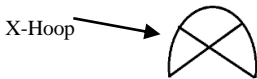

**Seat Belts:** Racing harnesses **MUST** be used and must be in good condition

**Helmet:** All drivers must wear a DOT approved helmet

No altering of suspension.

Must keep Stock Exhaust

Battery must be in stock location and securely fastened.

All cars must have tow hooks on front and rear.

No Tow hooks means no racing.

**The track and its tow crews will have no responsibility whatsoever for damage resulting from towing a disabled vehicle from the racing area.**

**Motorsports at all levels pose a risk to your wellbeing. Following the rules set for by Speedway 95 in no way guarantees or suggests your safety.**

**No Current Year Saturday Night Division Drivers will be allowed in this division**

**Any cars left at the race track for more than 7 days after racing for that division. Will be removed at the car owner's expense.**

## Just for Fun Class

### **Must have a separate vehicle from the RoadRunner**

Vehicles must be street legal for make and model except for modifications made for racing allowed by these rules. Passenger vehicles only. No convertibles, Full size vans, Full Size trucks, Chrysler Imperials, station wagon or full frame Oldsmobile Toronados. No leaf spring vehicles. No ALL wheel drive cars. **No turbochargers, No superchargers.**

**Seat Belts:** Must have a functioning seat belt of racing harnesses **MUST** be used and must be in good condition

**Fire Extinguishers:** Operative 3# fire extinguisher with gauge mounted in a metal bracket within reach of the driver is required.

**Exterior:** Doors must be chained shut with steel chain or may be welded  
All hubcaps must be removed.

**2 – 2” steel pipes or tubes on driver’s side required - passenger side door optional. All hubcaps must be removed.**

**Windshield:** Front windshield must be in place when racing. Windshield must be stock glass or Lexan™. All other glass i.e. headlights and marker lights must be removed from the vehicle before it will be allowed to compete. **No lights of any kinds will be allowed at any time.** Window Nets Mandatory

**Must remove all glass except the windshield and lights**

Top three will receive prize money and all other participants will have two pit passes at pit gate waiting to be picked up the following event.

All cars must have tow hooks on front and rear.  
No Tow hooks means no racing.

## Racing Stars of Tomorrow

### Wednesday Nights Ages 10 – 15\*

\*Must not be more than 15 years of age throughout the racing season

**No driving participation allowed in any racing division other than Racing Stars of Tomorrow, either on Wednesday or Saturday race meets.**

**CERTIFIED** copy of Birth Certificate AND current notarized minor release form to be on file with Speedway 95 Promotions, Inc. for the whole racing season. **ALL minor drivers must be accompanied in the pit area by a legal parent.**

1. 4 Cylinder Only
2. Fuel Cell REQUIRED
3. Saturday Safety Rules apply
4. Saturday Racing Rules apply
5. Four point roll cage REQUIRED (see page 17 & 18)
6. Full Racing Suit REQUIRED
7. Helmet REQUIRED
8. Gloves REQUIRED
9. Aluminum Seats ONLY
10. Right side head rest REQUIRED. Left Side OPTIONAL
11. Neck Collar REQUIRED
12. Racing Seat belts REQUIRED (five point harness)
13. Weight Rule: 53% left side weight,
14. No body alterations allowed
15. **All other rules will follow Modified Enduro Rules**  
All cars must have tow hooks on front and rear.

## Roll Cages

10. A four-point roll cage is mandatory in MODIFIED ENDURO and RACING STARS of TOMORROW Divisions. If roll cage is used it must be approved by safety. A roll cage must consist of four uprights joined together at all four corners at the top. Tubing must be at least 1 ½” Round O.D. and minimum .090 wall thickness. All roll cages must be professionally welded.
11. An “X” must be placed between the rear uprights, or a horizontal bar may be used to join the two rear uprights at the bottom, with a diagonal bar joining the top and bottom horizontal bars.
12. Four bars running between front and rear uprights are required on the driver’s side. These bars must be padded.
13. A minimum of three horizontal bars or an “x” is required on the passenger side of the vehicle.
14. A horizontal bar between the two front uprights just above or below the dashboard is required.
15. Forward or rearward bars attached to the main uprights are NOT allowed.
16. The roll cage may not reinforce the body or frame or alter the geometry of the vehicle.
17. Roll bars may NOT extend through firewalls.
18. All vehicles with frames must have the roll cage welded directly to the frame NOT the floorboards.
19. All vehicles without frames must use the sandwich method shown in the roll cage diagram to secure the roll cage to the vehicle.
20. May have rearward bars no further than firewall or center of strut towers

## SUGGESTED ROLL CAGE DESIGN

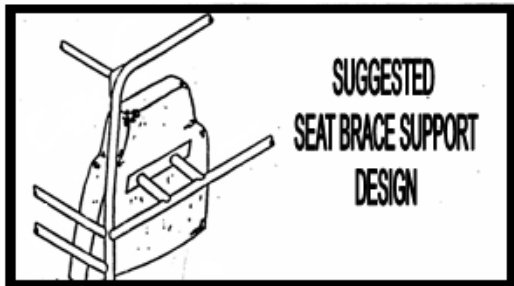
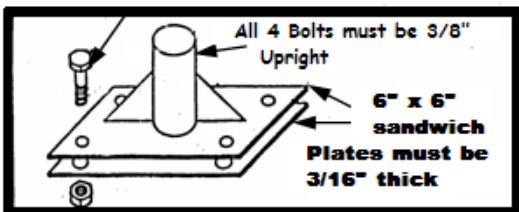
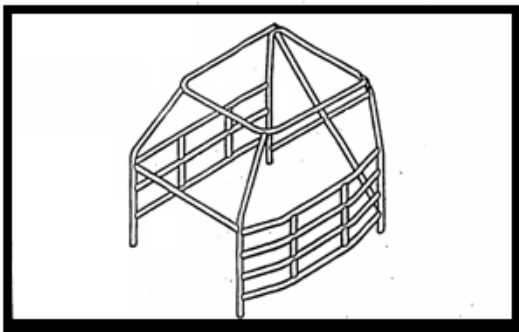

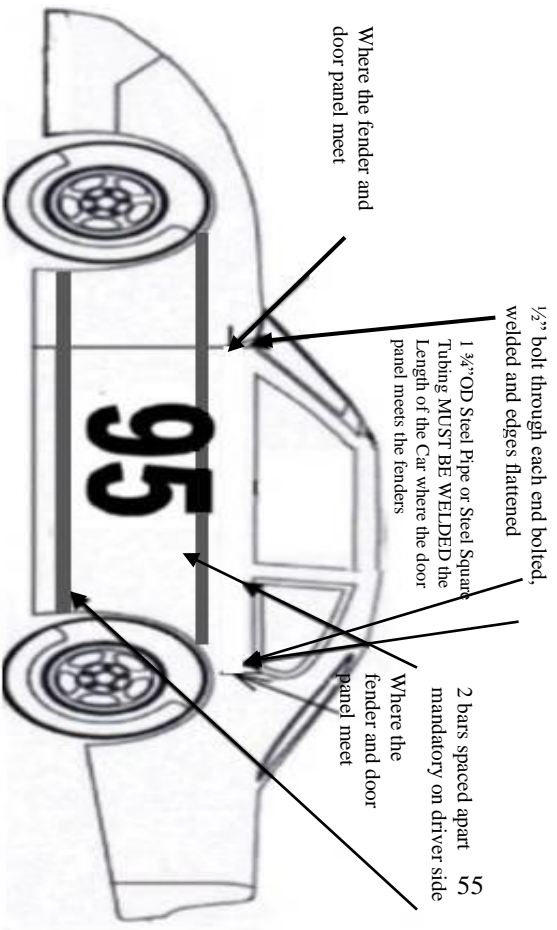

1/2" bolt through each end bolted, welded and edges flattened

1 3/4" OD Steel Pipe or Steel Square Tubing **MUST BE WELDED** the Length of the Car where the door panel meets the fenders

2 bars spaced apart 55 mandatory on driver side

Where the fender and door panel meet

Where the fender and door panel meet

Driver Side Mandatory –  
 Passenger side suggested but NOT Mandatory