



***2012 SEASON
RULES AND REGULATIONS
LATE MODEL,
SUPER STREET,
STRICTLY STREET AND
SPORT FOUR DIVISIONS***

2011 SPEEDWAY 95
RULES AND REGULATIONS

Rule Book Disclaimer

The rules and/or regulations set forth herein are designed to provide for the orderly conduct of racing events and to establish minimum acceptable requirements for such events. These rules shall govern the condition of all events, and by participating in these events, all participants are deemed to have complied with these rules. No express or implied warranty of safety shall result from the publications of or compliance with these rules and regulations. They are intended as a guide for the conduct of the sport and are no way a guarantee against injury or death to a participant, spectator or official.

The race director shall be empowered to permit minor deviation from any of the specifications herein or impose any further restrictions that, in his opinion, do not alter the minimum acceptable requirements. No express or implied warranty of safety shall result from such alteration of specifications. Any interpretation or deviation of these rules is left to the discretion of the officials. Their decision is final.

Since it would be both impractical and impossible to list within the confines of any rule book all modifications, adaptations, and infractions that could be or would be illegal, it shall be understood for the purpose of rule book enforcement that only those items that are specified in this booklet are allowable and permissible. In addition, Speedway 95 holds the rights to fine, suspend, eject and/or withhold purse and points from anyone who violates these rules.

Track Management

Track Management	Del Merritt	989-1226
Head Judge (vehicle numbers)	Kim (Baker) Allen	990-5034
Pit Steward	Henry Maynard	735-3378
Safety Director	Wayne Elston	848-5943
Tech Director	Tim Hamel	944-9459
Assistant Tech Director	Alan Jewett	327-1372

Point System For All Divisions

Feature winners in all divisions are awarded 100 points. Each position back is awarded two (2) less points than the previous position. Heat winners in all divisions are awarded 10 points for winning, and each position back receives two (2) points less than the previous position except 6th position receives one (1) point. No points are awarded for non-qualifier/consolation events in any division. Drivers must complete one lap under green flag conditions during a race meet to be eligible for points and purse.

Points are awarded to the driver. Purse money is paid to the person listed on the information sheet for that vehicle under "Check payable to". Any other arrangements are between that person and the driver.

Any discrepancy in points or finishes must be addressed within 2 weeks of event.

Competitor must compete in minimum of 3/4 of the scheduled race events to qualify for any trophies and point fund payout. Series Event competitors, must compete in 2/3 of scheduled series races.

Number Rules

- 1) All numbers will be assigned by Head Judge, Kim 990-5034. An assigned number may be retained for the following season if the driver assigned that number competed in at least ten (10) race meets during the previous season and the driver is remaining in the same division. When changing divisions, a new number will be assigned.
- 2) A minimum of 18 in. high and 3 in. wide **block style** number is required centered on the door area of both sides of the car. A minimum 30 in. high, 3 in. **wide block style** number is required to be located on the roof of the car and it must be readable from the right side of the car. A 20 in. high and 3 in. wide number must also be located on the trunk, readable from the rear. Numbers shall be painted neatly in a color contrasting that of the car. Windshield numbers at least 5 in. high are required on the far upper right-hand side of the windshield. All Sportsman cars must put a 5" S after the number on the windshield only (example 95S). A block style number as large as possible on the outer headlight and taillight covers is recommended.
- 3) Three digit numbers and fractions are not allowed. No new numbers will be issued with any number/letter combination.
- 4) All numbers must be kept in easily readable condition. If they are damaged in an accident, they must be fixed by the next race meet. Inability of the scorers to read numbers can result in the car being barred from competition until they are repaired to the satisfaction of head judge.

Line Ups

Heats:

- 1) All divisions will draw for starting positions. One heat for 13 or less cars, 14 or more cars will be divided into 2 heats.
- 2) Drivers who competed in the most recent race meet will be lined up ahead of those who did not; as follows: cars will be lined up for heat races of 13 or less cars in the order of the number that they draw, lowest number will start first. If 14 or more drivers draw for position at a race meet, heats will be divided into 2 heats and lined up as follows; the driver drawing the lowest number will start first in heat #1. The driver with the next lowest number will start first in heat #2. The 3rd lowest number will start second in heat #1, and so on, alternating between heats. The top 3 from the previous feature will start the heats in the position drawn as outlined above.
- 3) Any driver disqualified during technical inspection at a race meet will start at the rear of the line-up, behind ALL cars, in the qualifying heat and feature at the next race meet in which he/she participates.

Features:

- 1) Drivers who competed in the most recent race meet will be lined up according to where they qualified in the heat with the exception of the top 3 finishers of the previous race meet who will line up at the rear of this group regardless of where they qualified. Drivers not competing in the race meet prior to the current will be lined up behind the top 3 finishers of the race meet of the last feature event. Drivers who do not qualify will start the feature at the rear of the lineup.
- 2) All feature and championship events shall be run the full number of laps regardless of restarts barring unusual conditions such as rain, darkness, or the lateness of the hour. Feature events shortened by unusual conditions will have been completed under green flag conditions. If the event is called while being run under caution, the last full lap scored will be used to determine finishing positions. To be in final results the car must be on the track, others will be scored according to the number of laps they completed. Final results will be determined by track officials.
- 3) In case of tie finishes where a clear and convincing winner cannot be determined, the purses and points for both or all positions in question will be pooled and divided amongst the drivers involved.
- 4) In the event of a double feature caused by unusual conditions during the previous race meet, those cars and drivers not present at the postponed race meet will start at the rear of the make-up feature.
- 5) No car will be allowed to compete in more than one heat race under any circumstances. No qualified car will be allowed in any consolation race.

General Rules

Anyone who performs an act or participates in actions deemed by Speedway 95 officials to be detrimental to the sport or to Speedway 95 including, but not limited to verbal abuse of any Speedway 95 official, the consumption of or being under the influence of alcoholic beverages in the pit area during a race meet, the use of or being under the influence of drugs in the pit area during a race meet, fighting - which is defined as making or attempting to make physical contact or reckless operation of a race car or other vehicle in the pit area shall be disciplined appropriately by track management. Any person entering another pit area and causing conflict will be disciplined accordingly. Anyone who has signs of alcohol and/or drug use about their person will be asked to leave the premises. Any person using foul or abusive language toward any track official will be expelled without a refund.

PIT RULES

- 1) All persons in the pit area are under the control of the Pit Steward. Disobedience of the Pit Steward's directives is cause for expulsion from Speedway 95 property. **Speed limit in the pit Rules area is 5 mph for all vehicles.** Any speeding, pin wheeling or other such reckless conduct with any vehicle in the pit area will not be tolerated.
- 2) Everyone in the pit area must sign in at the pit gate and pay full admission price. Anyone under the age of 18, here after referred to as minors, must present a properly completed Speedway 95 Minor Release Form for the current year to the pit ticket takers and proof of paid admission before entering the pit.
- 3) Only vehicles towing a stock car are allowed in the pit area. All cars must be self-starting in the pit area prior to participation in the race meet.
- 4) Anyone under the age of 18, here after referred to as minors, must present a properly completed Speedway 95 Minor Release Form for the current year to the pit ticket takers and proof of paid admission before entering the pit.
- 5) Any person who has signs of liquor, drugs or firearms about him/her during a race meet shall be removed from the premises for the remainder of the meet and shall forfeit all doctor's and hospital fees for any injuries sustained during the race meet at which the offense occurred. The vehicle on either side of the Offending party may also be asked to vacate the premises.
- 6) No racecar will carry more than one person at any time it is in motion in the pit area or on the track. The only exception is during "Ride with your favorite driver".
- 7) No driver, owner, or mechanic will have any claim for damages, expenses or otherwise against track officials, owners, operators or promoters for disqualification, damage to car or driver, and agree that all conditions are safe when they participate in a meet.
- 8) If you are involved in an accident involving an injury to yourself, advise the racing officials immediately so that the necessary insurance reporting will be accomplished. Any person who refuses or does not seek medical treatment by the official medical team at the track forfeits any and all insurance protection.
- 9) **PIT TOWER ATTENDANT MUST BE NOTIFIED OF ANY CHANGE IN DRIVERS DURING A RACE MEET AND MUST BE NOTIFIED OF SAID CHANGE PRIOR TO THE RACE MEET.** If this is

not done prior to the running of the race, the driver/owner shall forfeit all purse, points, and position for the race in which the offense took place. Offending cars and/or drivers may be barred from the next meet. There will be no exceptions to this rule. If a car is disabled, the driver is eligible to borrow a different car registered to race in the same division. **Pit Tower Attendant must be notified of the change as noted above.** If the borrowed car is determined to be illegal at the conclusion of the race, the driver borrowing the car and competing with it will lose any points or purse for that race meet only.

- 10) Management will review all disputes and infractions, and reserves the right to decide on any disciplinary actions to be taken. Decisions will be made and the offending parties notified prior to the next regularly scheduled meet.
- 11) Any incident not covered by these rules may be decided upon by management and made a rule for the rest of the season.
- 12) No tires are to be left at the speedway. Disposal of tires and oil is the responsibility of the driver. Violators will be fined and/or suspended.

RACING RULES

- 1) Once a car is on the racing surface, it is under the control of the flagman and race director. Any disobedience of their directions or decisions may be cause for disciplinary action.
- 2) Any car assisted by the wrecker to get going will go to the rear.
- 3) Any car spinning out by itself causing a restart will be placed at the rear of the line-up at the restart. Cars purposely or intentionally accelerating during a spinout and endangering others in the process are subject to disqualification from that event. Any car spinning out by itself three times in the same race is subject to disqualification from that event.
- 4) There shall be no restart of an event because of a spinout or accident if, in the flagman's opinion, the track is not blocked and the driver is not injured or in immediate danger.
- 5) Any car leaving the line-up or going to the pit area must rejoin the field at the rear of the pack. In the event of an accident all unauthorized persons must remain in the pit area. Violation of this rule may cause disqualification of the car and/or driver for the remainder of the event. Owners are responsible for stressing this rule to their crew. "I didn't know" will not be accepted for an excuse - this is for your own safety to allow trained medical personnel unrestricted access to you in the event of an injury.
- 6) Rough riding, excessive track use and unsportsmanlike conduct of any kind is not permitted. Arguing with track officials and displays of temper with an automobile in front of the grandstand area are prohibited and will be dealt with severely. Climbing uninvited onto the flag stand at any time will be cause for disciplinary action. Complaints from drivers will not be heard in front of grandstand. Any drivers with a problem will proceed to the striped area on the backstretch where a track official will attempt to resolve the problem. Drivers will leave the striped area when told to or be subject to disqualification from the event.
- 7) Entrance from the pit area to the track is on the third turn. Exit from the track to the pit area is on the second turn. Violators are subject to disqualification from an event.

- 8) Any car on the racing surface, which is deemed by the Race Director or the Flagman to not be competitive may be asked to leave the racing surface by display of the black flag. If the car can again compete at racing speeds, it will be allowed to re-enter the race at track official's discretion.

- 9) Pole car has choice of inside pole or outside pole on restarts in both heats and/or features after original lap is completed. If the first lap is not completed, the line-up goes back to a complete and original lineup. Inside and outside pole drivers have the responsibility to stay even and set the pace for the start or restart. These drivers will not accelerate on starts or restarts until their cars are exiting turn 4 and have passed the white line on the track in turn 4. If the flagman is unable to display the green flag after two attempts because the pole sitters are not even or one has attempted to lay back to "slingshot" on the start, one or both may be sent to the rear of the line-up.

- 10) A driver or car owner may request to meet with any track official at the conclusion of the race meet provided the request is made to the Pit Steward within 15 minutes of the completion of the race in question.

- 11) The same car may not be driven in more than one division during the same race meet. No driver may change cars nor may any car change drivers during the running of a particular race.

- 12) Driver and track personnel shall not attempt to fix any car on the racing surface.

Flag Rules

Green Flag: The green flag signals the start or re-start of a race. On an original start, cars must remain in their position until they have crossed the start/ finish line. Any car getting out of line or passing before said start/finish line on the original start of a race will be penalized two positions for each car passed. On restarts, passing is allowed immediately after the green flag is displayed. Passing prior to the display of the green flag will result in a two position per car passed penalty, assessed at the conclusion of the event. All penalties will be assessed at the conclusion of the event.

Yellow Flag: The yellow flag signals caution. When the yellow flag is displayed, all cars must stop racing immediately and fall into single file in the position they were in when the flag was displayed. Cars should circle the track slowly until notified by track officials of any change in position. The flagman will notify scoring regarding the reason for the yellow and which car(s) caused the yellow flag to be thrown. These cars will be sent to the rear of the line-up. Cars will be lined up for the restart according to their scored position on the last completed green flag lap, except for those cars designated to go to the rear of the line up.. A lap is considered completed when all cars competing on said lap have crossed the start finish line. Any car going to the pit area while under caution will restart at the rear of the line-up. **We do not race to the yellow flag.**

Red Flag: The red flag means the race must be stopped immediately regardless of the cars position on the track. Red flag laps are not scored. After stopping, wait for the light to return to yellow or for the flagman to signal that it is safe to move. Cars should proceed to turn three and wait for a line-up.

White Flag: The white flag signals that a driver is entering the final lap of a race. The next flag will be the checkered flag unless a red flag is displayed because of an unsafe condition between the cars racing the final lap and the start/finish line.

Checkered Flag: The checkered flag means the race event is over. The first three cars, as determined by distance run, should proceed back to the start finish line for verification. Once released by the officials on the track, the first three cars must proceed directly to the technical inspection garage before returning to their pit areas. Failure to do so may result in disqualification and loss of purse and points for that meet.

Black Flag: The black flag is the consultation flag. When the black flag is displayed to a car, the driver must leave the racing surface for the pit area immediately. He will be informed in the pit area of the reason for the black flag. The black flag may be displayed for an infraction of the rules, in which case the driver is disqualified from further participation in that event only, and loses all points and purse for that event. If the black flag is displayed for a mechanical problem deemed by track officials to be hazardous to either the driver or other competitors, the car will be allowed to re-enter the event if the car is repaired. No purse or points will be withheld from a driver black flagged for mechanical problems.

SAFETY RULES

- 1) **Batteries:** Battery must be mounted within the car and must be securely bolted to the floor, mounted in a battery box and covered to prevent spillage. Batteries and fuel cells cannot be mounted in the same compartment. (Bombers excluded from this rule)
- 2) **Fire Extinguisher:** All cars in all divisions must carry an operative 3# minimum fire extinguisher with gauge that is within reach of the driver. All extinguishers must have a metal quick release-mounting bracket. No plastic brackets, tape, wire or other makeshift devices will be allowed.
- 3) **Window nets:** Window nets are required in all divisions and must be fastened to the roll cage and must be quick release with a seat belt type fastener. Window nets must be securely fastened at all times when a car is on the racing surface.
- 4) **Helmets:** All helmets must be of racing or motorcycle type and must be Snell approved. Helmets must be worn at all times when a car is on the racing surface.
- 5) **Drive shaft:** A drive shaft safety loop or under sling is required within 12" of the front universal joint. The drive shaft must be painted white.
- 6) **Brakes:** Four wheel brakes in proper working order are mandatory at all times. Brake shoes or pads must be mounted and operating on all four wheels (except Late Model division cars).
- 7) **Overflow can:** A four (4) quart minimum overflow can connected by hose to the radiator and mounted in the engine compartment is mandatory.
- 8) **Bumpers:** Bumpers must be welded to the frame for safety and must be stock in appearance. **NO BATTERING RAMS.** Rear bumper/bumper covers strapped to body or frame.
- 9) **Doors:** All doors must be welded shut.
- 10) **Fenders:** Fenders may be trimmed for tire clearance only. All trimmed edges must be rolled to eliminate rough edges.

- 11) **Hood:** Hood and trunk must be securely fastened down at all times. Enforcement of this rule is at the discretion of the flagman/race director, and his decision is final.
- 12) **Firewall:** All cars must have a steel firewall of at least .22 gauge thickness between the engine compartment and the passenger compartment as well as between the passenger compartment and the trunk area containing the fuel cell.
- 13) **Fuel Cell:** All cars must have a fuel cell with foam inside mounted in a box of no less than .22 gauge steel. All fuel cells must be securely fastened to the vehicle in the trunk area and have a minimum of 8" ground clearance. Fuel cells must have a vent hose with check valve. Vent hose must extend below fuel cell when car is in the upright position.
- 14) **Glass:** A full windshield of either safety glass or Lexan™ is required in all divisions. If a windshield is lost during a race meet, the driver may continue to race if he wears goggles or a full face shield and installs at least 1/4" mesh screen over the windshield area. Cracked or broken windshields must be cleared by the Safety Committee before a car will be allowed to compete.
- 15) **Steering Column:** Steering columns must be collapsible or have at least two (2) universal joints. Steering box "rag" joint and heim joints supporting steering column are not considered universal joints. Center of steering wheel must be padded. **All divisions must have quick disconnect steering wheels.**
- 16) **Roll Cage:** A full roll cage of four uprights joined at the top by a complete loop is required for all divisions. Front hoop and supporting bracing is mandatory. Front hoop is optional in Strictly Street Division. All piping must be at least 1 1/2" O.D. steel and welded 360 degrees. No galvanized pipe allowed. No threaded fittings or flattened ends will be allowed. Three (3) door bars on driver's side are mandatory, with proper bracing and gussets. Two (2) door bars with proper bracing and gussets are required on the "Passenger" side, with three strongly recommended. These bars may either follow the contour of the door or be square with front and rear uprights. A complete hoop is required overhead with at least one bar either diagonally across or front to rear. At least two braces must extend behind the rear uprights to a point on the frame at least three feet back. Bracing extending into the trunk area to protect the fuel cell is recommended. A horizontal bar between the two front uprights in the dashboard area is recommended. A driver side vertical "vent window" brace is recommended. A plate of at least 1/8" thickness is required to be welded and gusseted between the door bars and the body panel on the driver's

side. The plate should be located so as to protect the driver from foreign objects that may pierce body panel.

- 17) **Seats and seat belts:** aluminum seats are recommended in all divisions. If the fiberglass seat is used, it must be installed with mounting bolts reinforced with 1/8" x 3"x 6" plate both on the bottom mounting points and the back mounting points. Seats must be mounted attached to the roll cage. Seat belts must be airplane type quick release and capable of withstanding 3,000# body block test. The seat belts must be attached at two separate points on the roll cage equal distance from the center of the seat back and no less than twelve (12) inches apart. They must be attached with bolts having a minimum diameter of 1/2". Bolts must be aligned so that the direction of stress will be in direct line with the pull of the seat belt. If belts are attached to a steel plate attached to the frame, the plate must be a minimum of 1/4" thick. Shoulder straps are mandatory and must be securely fastened to the roll cage behind the driver's seat or to a 1/4" plate welded to the roll cage behind the driver's seat. Sternum and submarine (crotch) belts are highly recommended. Seat belts and helmets must have a date of manufacture not more than four years old. **5-point safety harness required, harnesses must have a date of manufacture not more than six years old unless approved by Safety Team.**
- 18) **Clothing:** All drivers in all divisions must wear an approved long sleeve fire retardant racing suit at all times when the vehicle is on the racing surface. This includes test and tune sessions. Racing suits must be free of rips, tears and holes, and have a date of manufacture of not more than four years old, to be checked a few times a year by the safety committee .
- 19) Any jack points protruding through the body panels must be approved by the Safety Committee. Safety Committee approved 1" rub rails mounted flush with body panels allowed in all divisions.
- 20) No boxing of the passenger side of the interior will be allowed if it prohibits the easy removal of the driver through the passenger side of the car.
- 21) All vehicles must have front and rear tow hooks made of 1/2" rolled steel and installed as a vertical loop. Late Model and Sportsman cars may make tow arrangements under the hood or trunk of the car. The track and its tow crews will have no responsibility whatsoever for damage resulting from towing a disabled vehicle from the racing area.

- 22) The Safety Committee has the right to disqualify any car from competition based on any infraction of the safety rules. Any infractions must be re-inspected before that car will be allowed to compete. The Safety Committee is responsible for the placement and visibility of numbers.
- 23) No anti-freeze in cooling systems. Water and KEEP KOOL™ quick cool only.
- 24) **Any weight added to vehicles must be lead only and painted white. Late Model and Sportsman drivers must wear Nomex™ racing gloves, and they are recommended in all other divisions. No Mechanics Gloves allowed.**

General Technical Rules

- 1) Except for Sport-Four Division, cars must be of domestic manufacture from 1965 to present. No convertibles, station wagons, vans or pick-up type vehicles. Bodies must be stock appearing and must have a complete roof. Rear wheel drive vehicles only, except for Sport-Four. No four wheel drive.
- 2) All cars must start the race meet with all body panels in place. Body components found to be illegal must be replaced before that vehicle will be allowed to compete. Removal of an illegal component once the race meet has begun does not make that car legal.
- 3) No equipment will be considered as having been approved by reason of having passed through inspection undetected. Any equipment which does not meet specifications or tolerances may not be eligible for approval.
- 4) All cars being weighed for compliance with technical rules will be weighed with each wheel centered on a scale, the driver belted in the seat and sitting in an upright position with his/her helmet on or resting in his/her lap.

Teardowns

- 1) Management or the Technical Committee may request a technical inspection of any car at any time. Refusal to submit to technical inspection is considered out of stock and will cause loss of purse and all accumulated points. Top three finishers in each feature must go directly from the track to the inspection area. If you go to your pit area first, you will be considered illegal and disqualified. Management reserves the right to exclude anyone from the inspection area at any time. Only those persons approved by the Technical Inspector are allowed in the inspection area.

- 2) When there is a specific question by other competitors in the same division regarding the legality of a particular part of a particular car, the following procedure must be followed in order to have the Tech Committee inspect that car:
 - a. Five (5) drivers competing in the same race meet as the car in question must notify the Pit Steward at least 15 minutes before that race that they desire an inspection of that particular part of that particular car.
 - b. Those drivers requesting the inspection must present \$500.00 and a technical inspection request form, available from the pit steward and prepared in the presence of the pit steward, to the pit steward.
 - c. If the car in question is found to be illegal, the money will be returned to the petitioners and the car will be disqualified from the race meet. If the car is found to be legal, the money will go to the owner of the car in question. Only one (1) petitioner will be allowed to observe the inspection.

- 3) Drivers of cars found to be illegal following an inspection by the Technical Committee will lose all points accumulated during that race meet. Any purse monies won during the race meet at which the car was found illegal will be forfeited.

- 4) Any car found to be in violation of technical rules may be subject to re-inspection before it will be allowed to compete again. For the purpose of rule enforcement, the term "STOCK" will mean of original equipment manufacturer (GM, Ford, Chrysler, etc.) Any aftermarket parts are allowed at the discretion of the Technical Inspector.

Late Model

BODIES: Bodies must be stock appearing, template type, and made of fiberglass, aluminum or steel. No altering of bodies except roof may drop 1" from a point in the center of the roof 10" behind front windshield to 10" before rear window. Windshields must be of 1/8" Lexan™ windshields must be securely mounted. Full rear windshield required and braced to prevent collapsing. No side windows attached to A or B post. Only drivers vents allowed in this area. Min ground clearance for all body parts is 3". Min roof height is 46". 5" X 60" spoiler maximum. Max height from ground to top of spoiler is 40". Spoilers cannot extend past bumper cover. No roof or window runners. No side boxing of spoiler. **No down force bodies.**

FRAMES: Frames may be fabricated with 2"X 3" or larger square steel tubing. Rear clip must be square tubing. 3" min ground clearance to lowest point with driver in car. Full Front stock clip must have stock steering box and stock type lower control arms. Front of spring pockets may be 2"X 3" square tubing.

WEIGHT: Minimum weight 2,800 lbs with GM crate motor #88958603 & #24502609, Ford crate motor #M60075347JR. Built motors up to 370 hp, 2,850 lbs, if motor is dyno tested and sealed at Butler & MacMaster Automotive. All others 2,900 lbs. All weights are AFTER the race with driver and all racing equipment in the car. Maximum left side weight is 56%. No allowance after race. All crate motors must be dyno tested and sealed with race track seals through Butler & MacMaster Automotive in order to receive weight break. No exceptions!

All cars being weighed for compliance with technical rules will be weighed with each wheel centered on a scale, the driver belted in the seat and sitting in the upright position with his/her helmet on or resting in his/her lap.

NOTE: GM crate motor #88958604 NOT ALLOWED!

SUSPENSION: No air/nitrogen adjustable shock absorbers. Any safety hub or heavy duty hub is mandatory on right front, optional on left front. Lower and upper A-frames may be tubular. Any sway bar allowed. Any Brake system allowed. No recirculators. Any rack and pinion steering system is allowed. Brakes must be working all four corners. Koni™ shocks ONLY. Models are KONI 30-1309 KON30-7436, KON30-9325, KON30-7325 and KON30-9436. No changing or altering valving. Track tech has right to replace or swap shocks at any time. No painting shocks. No bump stops on shocks. One (1) shock rubber as provided by manufacturer is allowed. Illegal tampering of shocks will result in disqualification and loss of all points for the season to date.

No traction control devices of any kind

Cars will be inspected using one and one half inch (1½") ramps, and nose of body must hit ground when pushed down by three crewmembers or will be considered illegal

WHEELS: Steel racing wheels limited to 8" maximum width. Maximum tread width allowable is 66 ½". Minimum wheelbase is 104".

TIRES: American Racer EC 84 and 85. Tires must be purchased from the authorized Speedway 95 track representative. No tire softener allowed. If caught with tire softener, driver will lose all points for season to date. The track has the right to make stiffer penalty if they deem it necessary. Once tires leave the truck, **ABSOLUTELY NO RETURNS.** Six (6) tires maybe purchased from the authorized track representative at the beginning of the season. Thereafter, one (1) new tire may be purchased from the authorized track representative for each feature event scheduled at a race meet and must be registered with the appointed official prior to being mounted on the car. Tires will be scanned into inventory. Six numbers will be kept in the car's tire inventory. Four registered tires must be on the car at the end of the race event or automatic disqualification will occur. Special event races will be exempt from this rule.

ENGINES: V-8: GM 305, 350 Ford 302, 351W Chrysler 318, 360. Engines may be bored .060" Oversize. Maximum compression ratio 11.0:1. Solid or hydraulic cam. **Engine must be centered plus or minus 1" for every 1/4" off center up to 1/2" add 50 lbs. to overall weight.** Measurement will be taken from inside frame rail to inside frame rail, in front of the crankshaft pulley. Steel cylinder heads only. World Product Jr.™ allowed. GM bowtie head # 25534371, Ford SVO cylinder head # m-6049-n352 and Ford cylinder head # M-6049-n351 will not be allowed. No porting or polishing allowed. Roller rockers allowed. Stock steel intake manifold or Edelbrock™ Performer Chevrolet 2101, 2104 or 2116, Ford 2181 or Dodge 2176. Stock steel crankshaft. Engine setback limited to #1 spark plug in line with ball joint centerline. **NO STROKERS.** Minimum distance from center of crankshaft to ground – 10 inches. No dry sump systems, any wet type. Oil pump must be in pan. GM Bowtie angle plug heads allowed 2.02 intake. No carbon fiber or titanium parts allowed. **A built sealed motor can have 1.5 rockers only.**

No roller cams or aluminum heads in built motor. Any steel straight plug max intake 1.94, All crate engines and built motors seeking a weight break must be sealed at Butler & MacMaster Automotive.

FUEL SYSTEM: Holley™ 4412 only. Stock fuel pumps. No electric fuel pumps. Carburetors bores must pass examination with track tech tool at top and bottom checkpoints. 1" spacers allowed. No tapered spacer.

EXHAUST: Any header allowed. Racing mufflers mandatory. No hollowed out mufflers. Exhaust is recommended to exit under car.

DISTRIBUTOR: Stock distributor. High output coil may be used. MSD™ allowed.

CLUTCH: Minimum 7 ¼" racing clutch. An inspection hole of at least 1" in diameter must be drilled in the bell housing to allow inspection of clutch and flywheel. **Steel flywheel only. Stock flywheel minimum weight is 15 lbs. Any built sealed or sealed crate motor allowed weight break of 50 lbs for stock clutch.**

TRANSMISSION: Any OEM three or four speed transmission allowed. **The only aftermarket transmission allowed is the Richmond™ OEM type T-10 casting four speed transmission Must have two forward gears with reverse working. High gear must be 1 to 1. No other forward gear can be any higher than 1.23 to 1. No Jericho™, Rankin™ Bert, Falcon or automatics allowed.**

REAR ENDS: Rear ends may be locked. **Maximum gear ratios allowed are 5.01:1 to 5.43:1.** Anything above or below will be disqualified. Rear end safety hubs recommended. Any rear end allowed.

IF IT IS NOT COVERED IN THESE RULES AND IT COST MORE THAN \$300.00 YOU MUST HAVE IT O.K.'d FIRST.

SPORTSMAN

Bodies:

Option #1: Stock body, stock roof and stock upper rear quarters Lower rear quarters doors and fenders may be aftermarket .22 gauge steel. All body dimensions must remain stock. Driver's side firewall and floorboards must remain stock. Bodies must be steel and remain stock appearing. May cut out right side floorboards. Fenders and door panels may be after market steel, no less than .22 gauge. Fiberglass hoods allowed. No dirt track bodies. Bumper covers may be used front and rear, all must closely resemble stock unit. No cutting more than 4" above the tire. No lowering of bodies on frames. No aluminum, fiberglass or light alloys will be allowed as substitute for stock body panels. No tunnels, air ducts are allowed. Minimum body height, measured from the center of the roof at a point 10" back from the windshield is 48". Roof cannot drop more than 1" front to rear and side to side. Rear spoiler no more than 5" tall, 60" wide and 38" maximum from ground to top of spoiler. Body and frame may interchange.

Option #2: Fiberglass Bodies ABC, All bodies must meet ABC spec (Quarter length, Nose Height and Length, Roof Height) Can make aluminum panels must meet ABC spec. **No Down Force Bodies.** Rear Spoiler no more than 5" tall, 60" wide and mounted at ABC spec height (40") from ground. Full Rear bumper cover required.

Frames:

Minimum height of any part of bodies or frame 3" height with driver in the car.

Weight: Minimum weight with driver in car at the end of a race 2,900 lbs

Fiberglass and Aluminum bodies + 50lbs

Stock bodies - 50lbs

Aluminum fabricated interior + 25 lbs

Stock steel floor pan and firewall Full -25lbs

Left side stock pan and firewall only -0

Outside shocks and 4 jacking bolts +25

602 crate motors -100

Maximum Left side weight is **56% (56/44)**.

Weight may added or subtracted for competition.

All cars being weighed for compliance with technical rules will be weighed with each wheel centered on a scale, the driver belted in the seat and sitting in the upright position with his/her helmet on or resting in his/her lap.

Suspension Upper A Frames may be tubular. Any stock A-frame that fits stock chassis mounting points may be used. Any stock spindle may be used within manufacturer's line. All steering components must remain stock except for the

outer tie rods which may be Heim™ joints and sleeves, aluminum or steel. Over the counter replacements parts that meet original specifications will be allowed. One piece Howe™ type sway bar allowed must be mounted in stock location on chassis. Up to 1 3/8" max OD permitted. May be adjustable on frame mounts. NO GRAND NATIONAL 3 PIECE SWAY BAR. Stock drag link only, except non-slotted Howe unit allowed. Springs must be similar in design to original and must be mounted in original position with stock pockets. No coil over springs. **Lowering blocks may be used in mounting rear leaf springs.** No boosters or overloads permitted. Front and rear adjustable cups allowed. One shock absorber per wheel in stock position. Jacking bolts and outside shocks allowed with weight added as noted above. Only NON ADJUSTABLE SHOCKS with sealed steel body. Retail value of any one shock cannot exceed \$75.00 **Track has right to replace, swap or buy shocks at any time. Track official has the right to purchase any shock on any car for \$75 each.** Coil springs may run solid or adjustable 3 point link. Panhard or J-Bar allowed. Four wheel brakes mandatory. No bump stops on shocks or frames. ONLY COLEMAN™ MONO BALL JOINTS OR STOCK BALL JOINTS.

Wheels: Steel racing wheels with max. 8" width. 1" lug nuts required on all four wheels. You may run up to 1/2" wheel spacer if you run 5/8" wheel studs. Any offset may be used as long as the tread width rule is met. Maximum track width allowed is 66 1/2" front and rear. Wheel base must remain stock for chassis being used plus or minus 1" period. Minimum wheelbase is 104".

Tires: Track tires only (American Racer 8" treaded 704 on left, 705 on right 225/235). Tires must be purchased from the authorized tire representative. **No tire softener allowed. If caught with tire softener driver will lose all points to date. Track has the right to make stiffer penalty if deemed necessary.** Six (6) tires may be purchased from the authorized track representative at the beginning of the season. Thereafter, one (1) new tire may be purchased from the authorized track representative for each feature event scheduled at a race meet and must be registered with the appointed official prior to being mounted on the car.

Once tires leave the truck ABSOLUTLY NO RETURNS

Engines: Small block V-8 only, limited to the following sizes: CHEVOLET 350, FORD 351W and CHRYSLER 360. All engines restricted to maximum 11.0:1 compression ratio. Blocks and heads must be standard production with standard external and internal measurements, except that engine blocks may be bored .060" over standard. No high performance options such as heads, etc. will be permitted. **NO STROKER MOTORS.** Max. valve size allowed is 1.94 intake and 1.60 exhaust. No carbon fiber or titanium parts allowed. 602 crate allowed must be sealed by Butler & MacMaster Automotive -100 lbs. weight break for 602 crate motor.

Engine set back limited to #1 spark plug in line with ball joint center line.

CAM SHAFT SPEC: Solid or Hydraulic cam shafts. Maximum gross valve lift is .450 measured at the valve. No roller cams permitted. Cams must be chain driven. No gear or belt driven allowed. 1.5 Roller rockers allowed. Minimum distance from center of crank shaft to ground – 11 inches.

Fuel system: Carburetor must be stock 2 barrel catalogued and available through regular dealer channels or Holley 4412, 500CFM. NO VDL Only modifications are choke removal, jet change, power valve change. Must pass tech tool. Maximum 1” spacer allowed. No tapered or beveled spacers allowed. Fuel pumps must be stock location. **To discourage use of specialty carburetor, Track tech has right to swap carburetor at any time.**

Electrical System: Stock distributors and coils for year and model of engine are permitted.

Cooling System: Any radiator that will fit under the hood is permitted. **No anti-freeze in cooling systems. Water and Keep Kool™ only.**

Intake Manifolds: Stock cast iron intake. 1” spacer allowed. Optional intake an Edelbrock™ performer Chevrolet 2101, 2104, or 2116, Ford 2181, or Dodge 2176. No beveled spacers.

Exhaust System: Manifolds or any headers allowed. 1 5/8” tube size. 3” collector size only. No Merge or stinger type collectors allowed. No ceramic coatings, paint only. Racing mufflers mandatory. No hollowed out mufflers. Exhaust must exit under car. 180 or over the top headers allowed.

Clutch: Stock clutch and pressure plate only. Stock steel flywheel. 15 lbs min. An inspection hole of at least 1” diameter must be drilled in bell housing to allow inspection of clutch and flywheel. After market hydraulic clutch pedal allowed.

Transmission: Standard production automatic, three or four speed standard transmissions which may be catalogued and available through regular dealer channels may be interchanged with manufacturer’s line. High gear must be 1 to 1 ratio. Forward gears must be O.E.M angle cut magnetic steel. All forward and reverse gears must be working, and gear ratios must remain stock for transmission used. No 2-speed power-glide automatics.

Rear End: Standard passenger car rear ends mounted in stock position only. Max final drive gear rule 5.88:1. Rear ends may be locked by welding spider gears or mini spool. No cambered tubes. 9” Fords permitted Floaters allowed. Rear coil spring cars may run pan hard bar
No Quick Change units allowed.

Brakes: Rear disk brakes allowed Ssteel calipers only on both front and rear. After market brake pedal allowed.

IF IT COST MORE THAN \$150.00 YOU MUST HAVE IT OK'ED FIRST.

**THE TECH COMMITTEE RESERVES THE RIGHT TO ADD OR
SUBTRACT WEIGHT AT THEIR DISCRETION FOR EACH ITEM
NOT MEETING SPEEDWAY 95 SPECIFICATIONS.**

**THE TECH COMMITTEE MAY ADD OR SUBTRACT WEIGHT IN THE
INTEREST OF COMPETITION.**

**Any alteration to any part of the car not specifically covered in these rules must
be cleared with the technical inspector or it will be considered illegal. In
other words, IF IT DOESN'T SAY YOU CAN DO IT, YOU CAN'T.**

**Any specification not covered by these rules may be decided upon by tech
management and made a rule for the rest of the season.**

STREET

Bodies: Cars must be of domestic manufacture from 1970 to present. Cars must be street legal for make and model. Passenger cars only. No convertibles, Vans, Station Wagons, pick-up truck type vehicles, Chrysler Imperials or Full Frame Tornados. Front or rear wheel drive. No four-wheel drive vehicles. Bodies may be changed from different manufacturers. **Stock bodies after market panels allowed per stock specifications.** Must be stock steel and must have a complete roof, floorboards, firewalls, and rocker panels. Doors may be replaced with .22 gauge steel, may run aftermarket bumper covers for body being run. Hoods may be replaced with fiberglass or aluminum with a 25# weight penalty. No other body alterations allowed. Cars must have wheelbase of minimum of 101". May remove inner body panels. No dirt or wedge type noses or tail pieces. All cars must start the race meet with all body panels in place. Body components found to be illegal must be replaced before that vehicle will be allowed to compete. Removal of an illegal component once the race meet has begun does not make that car legal. All doors must be welded shut. Cars may use 5" rear deck spoiler.

Frame: Must have a four-point roll cage but a full roll cage is suggested. Square tubing allowed from center of rear-end back, must follow be in stock position. Roll cage cannot be set back any closer than 24 inches from center of rear end.

Weight: Must weigh a minimum of **3,050** lbs with driver in the car Maximum Left side weight is 54% (54/46).
Under slung header 1 5/8" maximum allowed with 50 lbs penalty.

All cars being weighed for compliance with technical rules will be weighed with each wheel centered on a scale, the driver belted in the seat and sitting in the upright position with his/her helmet on or resting in his/her lap.

Suspension: Front and rear adjustable cups allowed. Upper control arms on rear end may be re-drilled. Lower rear control arm mounts may be moved up or down, must remain stock. Stock sway bars only in stock location stock frame mounts maybe adjustable on one side. Max diameter 13/8. Shocks must be stock replacement over the counter shocks or struts. No high performance. NO QA-1, ProShocks™, or adjustable shocks allowed. No reinforcement of brackets or suspension arms. Minimum height of any part of the body or frame for a Strut Camaro must be 6" all others cars 5" from the ground at the lowest point with driver in the car. All suspension parts must be stock for year, make, and model. Rear leaf spring cars may have adjustable shackles no longer than 6", lowering blocks allowed. No bump stops on shocks or frames. Leaf Springs must be steel and have a minimum of four (4) leafs .Leafs must be equal amount on both sides of the car. **Under slung header 1 5/8" maximum allowed with 50 lbs penalty.**

Wheels: May use aftermarket wheel. Track width no more than 64" . Must achieve track width with offset wheels, NOT suspension parts. Maximum wheel width seven (7) inches. May use aftermarket wheels minimum of 19 lbs.

Tires: American Racer 7" 225 SH or H track tire. Tires must be purchased from the authorized tire representative. No tire softener allowed. If caught with tire softener will lose all points to date. Track has the right to make stiffer penalty if deem necessary. Once Tires leave the truck ABSOLUTLY NO RETURNS

Engines: GM max engine size 350 plus .060 over . Ford max 351w plus .060 over Chrysler 360 plus 060 over. Engine block cylinder heads must be cast iron and O.E.M. stock. Crank shaft must be cast or forged. No modifications or lightening. Two valve relief pistons allowed. Stock steel connecting rods aftermarket stock replacement. Racing oil pan allowed. Cam shaft must be hydraulic flat tappet only. Stock lifter bore. Max. lift 450 at the valve. Stock type rockers. Ratio. Cylinder heads must be O.E.M. castings straight plug. World product head #4361 will be allowed. Vortex heads allowed. Max valve size 1.94 intake 1.6 exhaust. Intake must be stock O.E.M. cast iron 2 barrel or 2101 or 2116 aluminum ONLY may be used. Max compression 10.2:1.

Carburetors: Will be stock Holly™ 4412. **No VDL's.** Only modifications are the removal of choke plate assembly, jet change, power valve change and accelerator pump change. No adjustable or changeable air bleeds. Must pass tech tools. Rochester™ unaltered 2 barrel allowed may change jets. Must pass tech tools. To discourage the use of specialty carburetors the track has the right to swap carburetor at any time. Must use MR gasket™ # 1929 or #1937. No exceptions. Rochester™ must not use more ½" gasket. Ignition stock O.E.M. only.

Cast iron water pump. Fuel Cells: May be mounted through trunk floor. Securely fastened to car. Fuel Cell minimum ride height 12" from the ground. No adjustable or sliding spacers.

Exhaust: O.E.M. log type cast iron manifolds. No ram horn manifolds. Racing mufflers mandatory. Exhaust must exit under car pointed toward the track. If the track deemed your race car to be too loud you will be required to run track muffler.

Bumpers: Must remain stock appearing. After market bumper covers allowed for year, make and model. Malibu may use Monte Carlo SS front and rear bumper covers. 1990 and newer Thunderbirds may use 1985 Thunderbird nose and rear bumper covers.

Glass: All window glass (except for windshield) must be removed. All broken glass must be removed from the car before it will be allowed to compete.

Transmission: Stock cast iron 3 speed. All gears must be working. Stock steel fly wheel and stock clutch. Automatic transmissions allowed. NO 2 speed power glides. Stock torque convertors only.

Rear End: Locked rear ends allowed. Maximum rear gear 3.73. No cambered rear ends. Standard 3 speed only 557 final drive.

Radiator: No anti freeze allowed. **Water and Keep Kool™ only.** All cars must have an overflow jug in working order.

Battery: Battery may be moved to behind the driver's seat or remain in stock location.

Brakes: All cars must have four wheel brakes in working condition.

IF IT COST MORE THAN \$100.00 YOU MUST HAVE IT OKED FIRST.

**THE TECH COMMITTEE RESERVES THE RIGHT TO ADD OR
SUBTRACT WEIGHT AT THEIR DISCRETION FOR EACH ITEM
NOT MEETING SPEEDWAY 95 SPECIFICATIONS.**

**THE TECH COMMITTEE MAY ADD OR SUBTRACT WEIGHT IN THE
FAIRNESS OF COMPETITION**

Any alteration to any part of the car not specifically covered in these rules must be cleared with the technical inspector or it will be considered illegal. In other words, IF IT DOESN'T SAY YOU CAN DO IT, YOU CAN'T.
Any specification not covered by these rules may be decided upon by tech management and made a rule for the rest of the season.

SPORT- FOUR

Bodies: The Sport- Four Division will be made up of 1970 to current model production cars. All body parts must remain stock bodies, except for cutting for installation of roll cage or tire clearance. Doors may be replaced with .22 gauge steel, no other body alterations allowed. Inner fenders in front of struts may be removed. After market bumper covers allowed. 4" rear deck spoiler allowed.

Frame: Front firewall must be stock. All holes to engine compartment must be covered with sheet metal. Firewall must be steel. Rear firewall must cover the entire area so that the trunk area is completely separated from the driver's compartment. The rear firewall must be steel. No aluminum. **Full stock floorboards are mandatory.** No fabricated frame rails. All rusted or damaged frame rails must be replaced with stock pieces. All floorboards must remain visible. No tinning in of interior. Seats may be replaced with a racing type seat and must be attached securely to the roll cage. Fiberglass seats must have 1/8" x 6" x 3" plate reinforcing the bolt holes on the bottom and back. A full roll cage is required, with a minimum of three (3) horizontal bars in the driver's door and two (2) on the passenger side. No butt welded joints. A vertical vent window bar is recommended. All roll bars within range of the driver must be padded. All cars must start the race meet with stock hoods and fenders. Hoods and trunk must be on original hinges. Any part that has had markings or parts I.D. numbers removed or altered will be considered out of stock. **NO HIGH PERFORMANCE PARTS.** High performance parts shall mean any part listed in parts books as high performance, special performance or special order parts. Minimum height of any part of the body or frame is 4" from the ground at the lowest point with driver in the car.

Weight: Minimum weight 2,000 lbs for 2,000 cc engines or under, 100 lbs per cc over 2,000 cc, including driver. Any added weight must be bolted to the frame rails with a minimum of four (4) 3/8 in. bolts, and must be painted white. Maximum left side weight 55% (55/45). Any cars with a square tube front frame forward of the strut towers or behind rear axle center line add 50 lbs per each end.

All cars being weighed for compliance with technical rules will be weighed with each wheel centered on a scale, the driver belted in the seat and sitting in the upright position with his/her helmet on or resting in his/her lap.

Track Width: 61". **Any exception must be tech approved.**

Wheels: Any steel wheels must be maximum 7" width to maintain 61" track width. Spacers allowed

Tires: American Racer 13" or 14" Track tire to be determined or any radial no less than 60 series. Tires must be purchased from the authorized Speedway 95 tire representative. Buffing Allowed. **No tire softener allowed. If caught with/using tire softener driver will lose all accumulated points to date.**

Once Tires leave the truck ABSOLUTLY NO RETURNS

Engine Specifications: In-line or horizontally opposed four cylinder engines stock for make and model of car only .030 overbore allowed. Keith Black™ cast piston allowed, flat tops only. No rotary (Wankel™) engines. 2.4 Liter max.

- 1) Heads must remain stock. No alterations allowed. Maximum compression ratio 10.2:1.
- 2) Cam not over .450 max lift. Stock sounding idle under 800 RPM. Aftermarket cam gears and under drive pulleys allowed.
- 3) **Holley™ 500 allowed;** or stock fuel injection. **No VDL's.** Fuel pump must remain stock and unaltered. An oil pressure switch is required for electric fuel pump units. **NO TURBOCHARGERS.**
- 4) Ignition must remain stock for make and model year.
- 5) Oil pan must remain stock and unaltered for make and model year.

Exhaust: Exhaust system must contain stock manifold for make and year. Exhaust pipe may exit behind door. **HEADERS ALLOWED.** No alterations to body for header installation. Racing mufflers mandatory.

Ignition: All cars must be equipped with a starter and be self- starting.

Fuel Cell: A fuel cell is mandatory. All fuel cells must be mounted in the trunk area and endorsed in a .22 gauge canister. Maximum capacity 15 gals. A check valve must be installed in the vent line. Fuel Cell minimum ride height 8" from ground.

Transmission: All running gear components, clutch, transmission, rear end, transaxle, etc. must remain stock and unaltered for make and model year. Ok to weld the rears but no aftermarket posi-track or Detroit™ type locking units. No cambered rear ends.

Chassis and Suspension: No independent suspension rear wheel drive. Wheelbase must remain stock and unaltered for make and model year. **Wheelbase stock for year make and model.** Straight up camber on rear of rear wheel drive cars, ½" +/- rear camber on front wheel drive cars ONLY. Front camber may be 2" on right side, 1" on left side. Shocks must be stock replacement over the counter shocks and struts. **NO** high performance, QA-1, Pro Shocks or

adjustable shocks allowed. No bump stops on shocks or frames. Only two (2) shocks allowed per axle.

Windshield: Windshield may be replaced with plastic or Lexan™. Complete windshield opening must be covered. No other glass allowed.

Brakes: Four wheel brakes in proper working order are mandatory. Brake system must remain stock for make and model.

Radiator: Any radiator may be used as long as no cutting of the hood or grill is needed for installation. All cars must have a one (1) qt. overflow catch can connected to the radiator that can be easily emptied.

Anything not covered by any rules for this division shall remain stock as made by the manufacturer. Stock for year and make must apply in all cases.

THE TECH COMMITTEE RESERVES THE RIGHT TO ADD OR SUBTRACT WEIGHT AT THEIR DISCRETION FOR EACH ITEM NOT MEETING SPEEDWAY 95 SPECIFICATIONS.

THE TECH COMMITTEE MAY ADD OR SUBTRACT WEIGHT IN THE FAIRNESS OF COMPETITION

Any alteration to any part of the car not specifically covered in these rules must be cleared with the technical inspector or it will be considered illegal. In other words, IF IT DOESN'T SAY YOU CAN DO IT, YOU CAN'T.

Any specification not covered by these rules may be decided upon by tech management and made a rule for the rest of the season.

BOMBERS

Cars must remain stock. No alterations allowed. Front wheel drive (FWD)
Passenger cars only. **NO SPORT CARS. NO ALL WHEEL DRIVE CARS ALLOWED.** All window glass (except windshield), headlights, and marker lights must be removed from car before it will be allowed to compete. Doors need to be welded or chained shut. **FOUR POINT CAGE NOT REQUIRED BUT HIGHLY RECOMMENDED.** Padding of steering wheel and door bars required. **TOW HOOKS FRONT AND REAR REQUIRED. NO SPOILERS.**

Tires: Stock for the car. No high performance tires. 1” tire tilt on left and right front allowed. 7” max tire width. All tire same size all round the cars.

Wheel: Stock for car 7: max width

Battery: Battery may remain in stock location or may be placed behind the driver’s seat in a box completely covering the battery.

Fuel Tank: Stock fuel tank, boat tank or fuel cell allowed.

Safety: FIRE SUITS HIGHLY RECOMMENDED

All drivers must wear a DOT approved helmet.

Working seat belts are required, approved by Safety Committee. 5-point safety harness highly recommended.

All cars must have an operating 3lb fire extinguisher with gauge mounted within reach of driver.

Air bags must be Removed and Disarmed.

Brakes: All four wheels must have working brakes.

Cars will race 20 laps or Maximum of 20 minutes.

SUGGESTED ROLL CAGE DESIGN

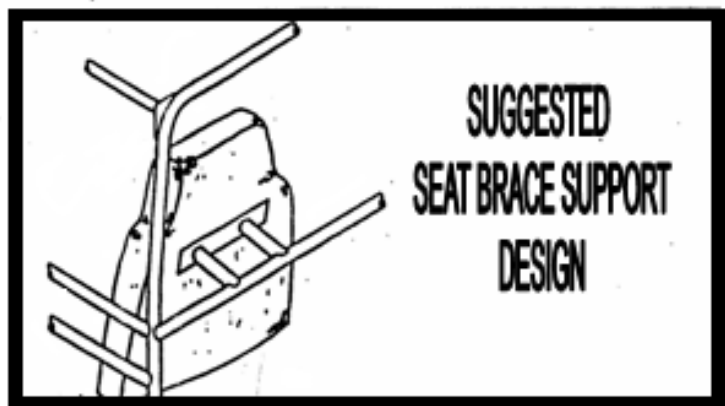
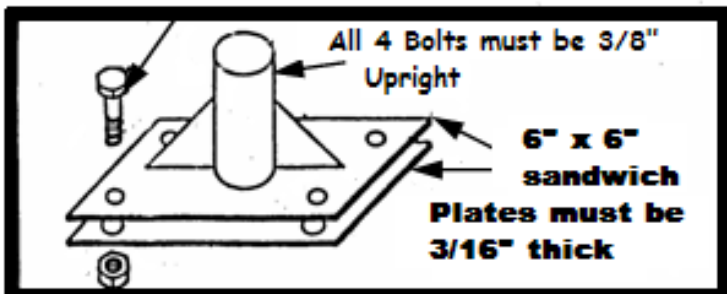
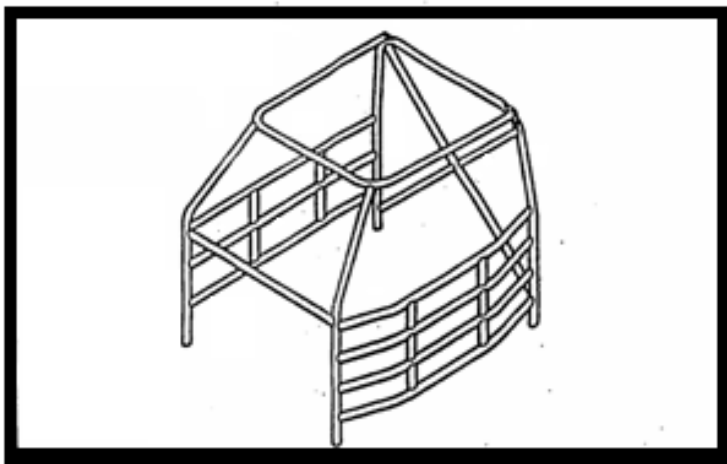

**Speedway 95
26 Nottingham Way
Brewer, ME 04401**